

DEPARTMENT OF THE ARMY TECHNICAL MANUAL

TM 11-5054

DEPARTMENT OF THE AIR FORCE TECHNICAL ORDER

TO 16-40BC614-6

---

# SPEECH AMPLIFIER

## BC-614-E, -F, -H, AND -I

---

*DEPARTMENTS OF THE ARMY AND THE AIR FORCE*

*OCTOBER 1952*



*TM 11-5054/TO 16-40BC614-6*

*This manual supersedes TM 11-4043, 11 October 1945*

---

# SPEECH AMPLIFIER

## BC-614-E, -F, -H, AND -I



---

*United States Government Printing Office  
Washington : 1952*

DEPARTMENTS OF THE ARMY AND  
THE AIR FORCE

WASHINGTON 25, D. C., 3 October 1952

TM 11-5054/TO 16-40BC614-6 is published for the information and guidance of all concerned.

[AG 413.44 (26 Aug 52)]

BY ORDER OF THE SECRETARIES OF THE ARMY AND THE AIR FORCE:

OFFICIAL:

WM. E. BERGIN  
*Major General, USA*  
*The Adjutant General*

J. LAWTON COLLINS

*Chief of Staff, United States Army*

OFFICIAL:

K. E. THIEBAUD  
*Colonel, USAF*  
*Air Adjutant General*

HOYT S. VANDENBERG

*Chief of Staff, United States Air Force*

DISTRIBUTION:

*Active Army:*

Tech Svc (1); Tech Svc Bd (1); AFF Bd (ea Svc Test Sec) (1); AFF (5); AA Comd (2); OS  
Maj Comd (5); Base Comd (5); Log Comd (5); A (20); MDW (5); CHQ (2); FT (2); Sch  
(5) except 11 (25); Gen Dep (2); Dep 11 (20) except Sig Sec, Gen Dep (10); Tng Div (2);  
POE (10), OSD (2); Lab 11 (5); Mil Dist (3); 4th & 5th Ech Maint Shops 11 (3); Two (2)  
copies to each of the following T/O & E's: 11-107; 11-127A; 11-128; 11-500, CA, CB, CC,  
CD; 11-587; 11-592; 11-597.

*NG:* Same as Active Army except one copy to each unit.

*ORC:* Same as Active Army except one copy to each unit.

For explanation of distribution formula, see SR 310-90-1.

## CONTENTS

	<i>Paragraphs</i>	<i>Page</i>
<b>CHAPTER 1. INTRODUCTION</b>		
<i>Section I.</i> General.....	1, 2	1
<i>II.</i> Description and data.....	3-10	1
<b>CHAPTER 2. OPERATING INSTRUCTIONS</b>		
<i>Section I.</i> Service upon receipt of Speech Amplifier BC-614-(*). . . . .	11-15	7
<i>II.</i> Controls and instruments.....	16, 17	8
<i>III.</i> Operation under usual conditions.....	18-20	10
<i>IV.</i> Operation under unusual conditions.....	21-24	11
<b>CHAPTER 3. PREVENTIVE MAINTENANCE INSTRUCTIONS</b>		
<i>Section I.</i> Preventive maintenance services.....	25-28	12
<i>II.</i> Weatherproofing and lubrication.....	29, 30	13
<b>CHAPTER 4. THEORY</b> .....	31-40	14
<b>5. FIELD MAINTENANCE INSTRUCTIONS</b>		
<i>Section I.</i> Trouble shooting at field maintenance level.....	41-47	27
<i>II.</i> Repairs.....	48, 49	36
<i>III.</i> Alinement procedures.....	50-52	36
<i>IV.</i> Final testing.....	53-62	37
<b>CHAPTER 6. SHIPMENT AND LIMITED STORAGE AND DEMOLITION TO PREVENT ENEMY USE</b>		
<i>Section I.</i> Shipment and limited storage.....	63, 64	42
<i>II.</i> Demolition of matériel to prevent enemy use.....	65, 66	42
<b>APPENDIX I. REFERENCES</b> .....		47
<b>II. IDENTIFICATION TABLE OF PARTS</b> .....		49
<b>INDEX</b> .....		59

## WARNING

### HIGH VOLTAGE

is used in the operation  
of this equipment.

### DEATH ON CONTACT

may result if operating personnel fail  
to observe safety precautions.



#### RESCUE.

In case of electric shock, shut off the high voltage at once and ground the circuits. If the high voltage cannot be turned off without delay, free the victim from contact with the live conductor as promptly as possible. Avoid direct contact with either the live conductor or the victim's body. Use a dry board, dry clothing, or other nonconductor to free the victim. An ax may be used to cut the high-voltage wire. Use extreme caution to avoid the resulting electric flash.

#### SYMPTOMS.

a. Breathing stops abruptly in electric shock if the current passes through the breathing center at the base of the brain. If the shock has not been too severe, the breath center recovers after a while and normal breathing is resumed, provided that a sufficient supply of air has been furnished meanwhile by artificial respiration.

b. The victim is usually very white or blue. The pulse is very weak or entirely absent and unconsciousness is complete. Burns are usually present. The victim's body may become rigid or stiff in a very few minutes. This condition is due to the action of electricity and is not to be considered rigor mortis. Artificial respiration must still be given, as several such cases are reported to have recovered. The ordinary and general tests for death should never be accepted.

#### TREATMENT.

a. Start artificial respiration immediately. At the same time send for a medical officer, if assistance is available. Do not leave the victim unattended. Perform artificial respiration at the scene of the accident, unless the victim's or operator's life is endangered from such action. *In this case only*, remove the victim to another location, but no farther than is necessary for safety. If the new location is more

than a few feet away, artificial respiration should be given while the victim is being moved. If the method of transportation prohibits the use of the Shaeffer prone pressure method, other methods of resuscitation may be used. Pressure may be exerted on the front of the victim's diaphragm, or the direct mouth-to-mouth method may be used. Artificial respiration, once started, must be continued, without loss of rhythm.

b. Lay the victim in a prone position, one arm extended directly overhead, and the other arm bent at the elbow so that the back of the hand supports the head. The face should be turned away from the bent elbow so that the nose and mouth are free for breathing.

c. Open the victim's mouth and remove any foreign bodies, such as false teeth, chewing gum, or tobacco. The mouth should remain open, with the tongue extended. Do not permit the victim to draw his tongue back into his mouth or throat.

d. If an assistant is available during resuscitation, he should loosen any tight clothing to permit free circulation of blood and to prevent restriction of breathing. He should see that the victim is kept warm, by applying blankets or other covering, or by applying hot rocks or bricks wrapped in cloth or paper to prevent injury to the victim. The assistant should also be ever watchful to see that the victim does not swallow his tongue. He should continually wipe from the victim's mouth any frothy mucus or saliva that may collect and interfere with respiration.

e. The resuscitating operator should straddle the victim's thighs, or one leg, in such manner that:

(1) the operator's arms and thighs will be vertical while applying pressure on the small of the victim's back;

(2) the operator's fingers are in a natural position on the victim's back with the little finger lying on the last rib;

(3) the heels of the hands rest on either side of the spine as far apart as convenient without allowing the hands to slip off the victim;

(4) the operator's elbows are straight and locked.

f. The resuscitation procedure is as follows:

(1) Exert downward pressure, not exceeding 60 pounds, for 1 second.

(2) Swing back, suddenly releasing pressure, and sit up on the heels.

(3) After 2 seconds rest, swing forward again, positioning the hands exactly as before, and apply pressure for another second.

g. The forward swing, positioning of the hands, and the downward pressure should be accomplished in one continuous motion, which requires 1 second. The release and backward swing require 1 second. The addition of the 2-second rest makes a total of 4

TL 15338-D

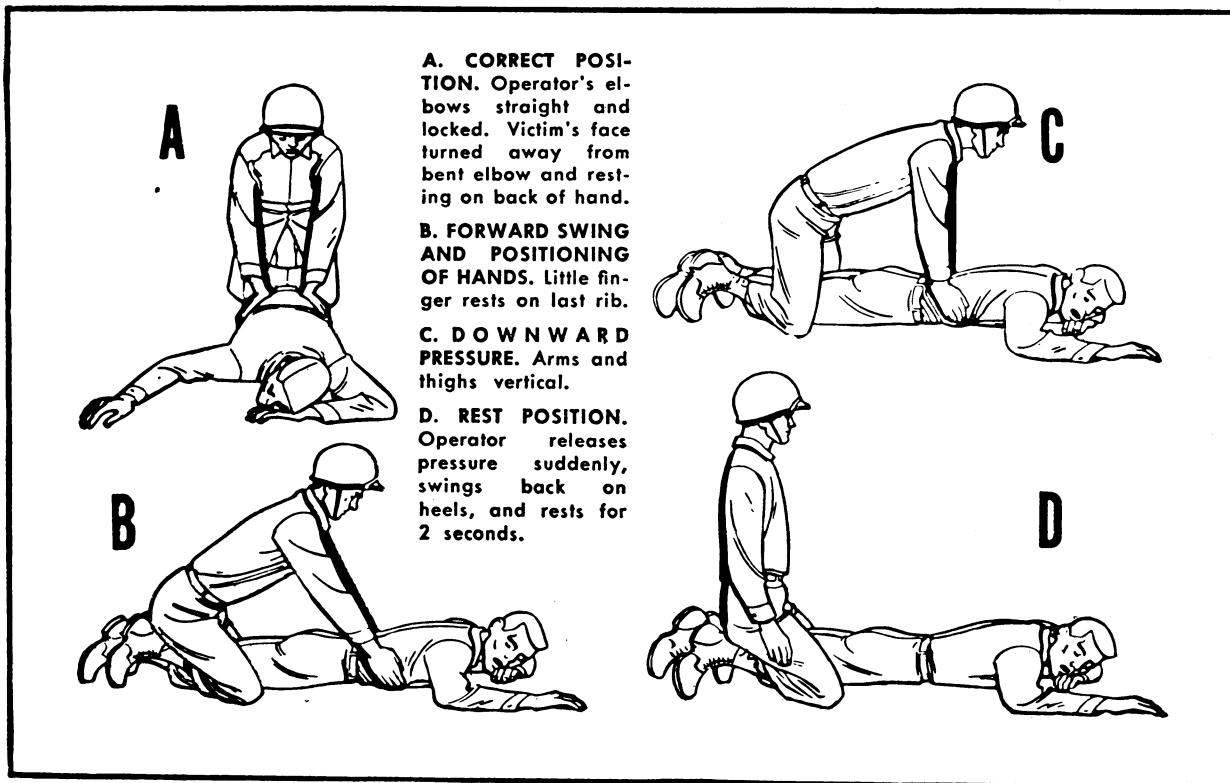

**A. CORRECT POSITION.** Operator's elbows straight and locked. Victim's face turned away from bent elbow and resting on back of hand.

**B. FORWARD SWING AND POSITIONING OF HANDS.** Little finger rests on last rib.

**C. DOWNWARD PRESSURE.** Arms and thighs vertical.

**D. REST POSITION.** Operator releases pressure suddenly, swings back on heels, and rests for 2 seconds.

seconds for a complete cycle. Until the operator is thoroughly familiar with the correct cadence of the cycle, he should count the seconds aloud, speaking distinctly and counting evenly in thousands. Example: one thousand and one, one thousand and two, etc.

h. Artificial respiration should be continued until the victim regains normal breathing or is pronounced dead by a medical officer. Since it may be necessary to continue resuscitation for several hours, relief operators should be used if available.

**RELIEVING OPERATOR.**

The relief operator kneels beside the operator and follows him through several complete cycles. When the relief operator is sure he has the correct rhythm, he places his hands on the operator's hands without applying pressure. This indicates that he is ready to take over. On the backward swing, the operator moves and the relief operator takes his position. The relieved operator follows through several complete cycles to be sure that the new operator has the correct rhythm. He remains alert to take over instantly if the new operator falters or hesitates on the cycle.

**STIMULANTS.**

a. If an inhalant stimulant is used, such as aro-

matic spirits of ammonia, the individual administering the stimulant should first test it himself to see how close he can hold the inhalant to his own nostril for comfortable breathing. Be sure that the inhalant is not held any closer to the victim's nostrils, and then for only 1 or 2 seconds every minute.

b. After the victim has regained consciousness, he may be given hot coffee, hot tea, or a glass of water containing 1/2 teaspoon of aromatic spirits of ammonia. *Do not give any liquids to an unconscious victim.*

**CAUTIONS.**

a. After the victim revives, keep him LYING QUIETLY. Any injury a person may have received may cause a condition of shock. Shock is present if the victim is pale and has a cold sweat, his pulse is weak and rapid, and his breathing is short and gasping.

b. keep the victim lying flat on his back, with his head lower than the rest of his body and his hips elevated. Be sure that there is no tight clothing to restrict the free circulation of blood or hinder natural breathing. Keep him warm and quiet.

c. A resuscitated victim must be watched carefully as he may suddenly stop breathing. *Never leave a resuscitated person alone until it is CERTAIN that he is fully conscious and breathing normally.*

TL 15338-E

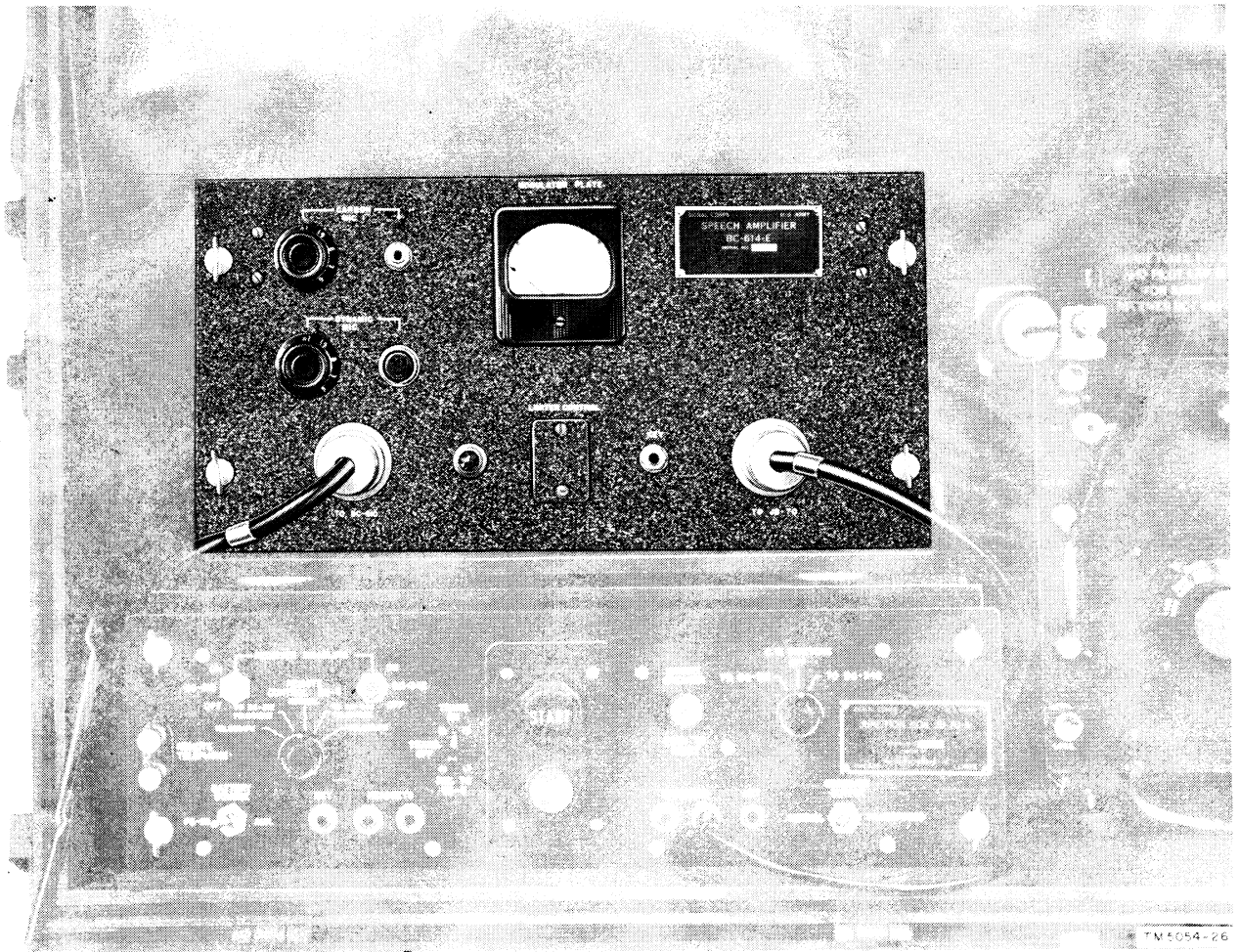

Figure 1. Speech Amplifier BC 614 E.



# CHAPTER 1

## INTRODUCTION

---

### Section I. GENERAL

#### 1. Scope

*a.* This technical manual contains information for the installation, operation, maintenance, and repair of Speech Amplifier BC-614-(\*). In addition, there are two appendixes covering a list of references and an identification table of parts.

*b.* Official nomenclature followed by (\*) is used to indicate all models of the item of equipment included in this manual. Thus Speech Amplifier BC-614-(\*) represents Speech Amplifiers BC-614-E, -F, -H, and -I.

#### 2. Forms and Records

The following forms will be used for reporting unsatisfactory conditions of Army matériel and equipment.

*a.* DD Form 6, Report of Damaged or Improper Shipment, will be filled out and forwarded as prescribed in SR 745-45-5 (Army); and AFR 71-4 (Air Force).

*b.* DA Form 468, Unsatisfactory Equipment

Report, will be filled out and forwarded to the Office of the Chief Signal Officer as prescribed in SR 700-45-5.

*c.* USAF Form 54, Unsatisfactory Report, will be filled out and forwarded to Commanding General, Air Matériel Command, Wright-Patterson Air Force Base, Dayton, Ohio, as prescribed in SR 700-45-5 and AFR 65-26.

*d.* DA AGO Form 11-238, Operator First Echelon Maintenance Check List for Signal Corps Equipment (Radio Communication, Direction Finding, Carrier, Radar), will be prepared in accordance with instructions on the back of the form.

*e.* DA AGO Form 11-239, Second and Third Echelon Maintenance Check List for Signal Corps Equipment (Radio Communication, Direction Finding, Carrier, Radar), will be prepared in accordance with instructions on the back of the form.

*f.* Use other forms and records as authorized.

### Section II. DESCRIPTION AND DATA

#### 3. Purpose and Use

*a.* Speech Amplifier BC-614-(\*) is an a-f (audio-frequency) amplifier which is designed for use with Radio Transmitter BC-610-(\*) or a similar transmitter. The basic purpose of the speech amplifier is to raise a microphone output to a suitable level for driving the input of the audio circuit in the transmitter.

*b.* The speech amplifier also provides sidetone for monitoring, by means of a headset, outgoing c-w (continuous-wave) transmissions.

*c.* The speech amplifier contains its own plate and filament supply which draws approximately 40 watts from the 115-volt, 50/60 cycle, a-c (alternating-current) source. The a-c supply is

fed into the speech amplifier through connector SO-103 (SO-104 in the BC-610-F) marked TO BC-610. When Radio Transmitter BC-610-(\*), or equal, is used, the FILAMENT POWER switch on the transmitter turns the speech amplifier on and off.

#### 4. System Application

(fig. 2)

*a. General.* Speech Amplifier BC-614-(\*) is designed for use in several radio communications systems, such as Radio Sets AN/GRC-26A, AN/MRC-2(\*), SCR-399-(\*), and SCR-499-(\*). In each of these systems, the fundamental application of the speech amplifier is the same; the

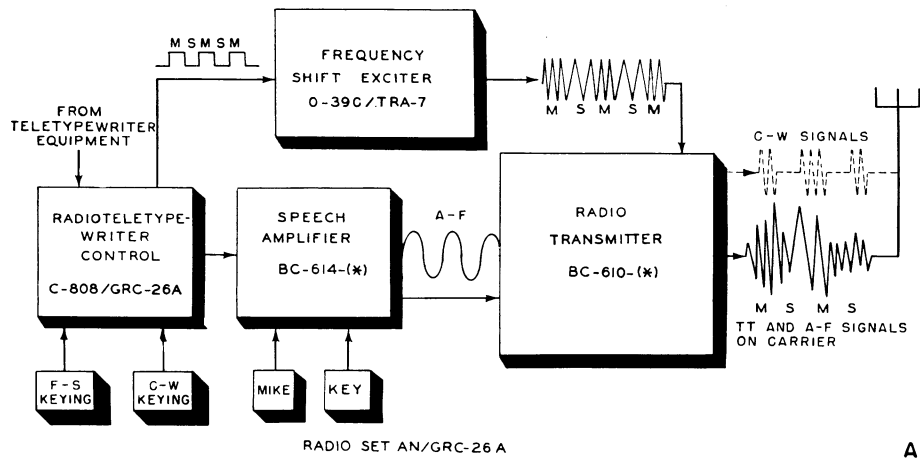

A

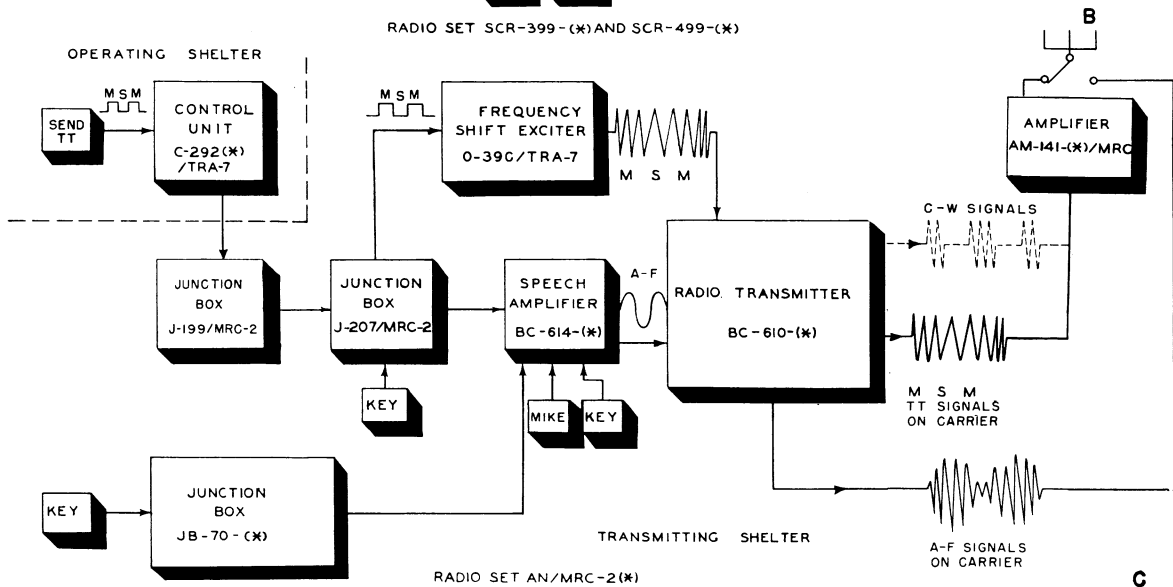
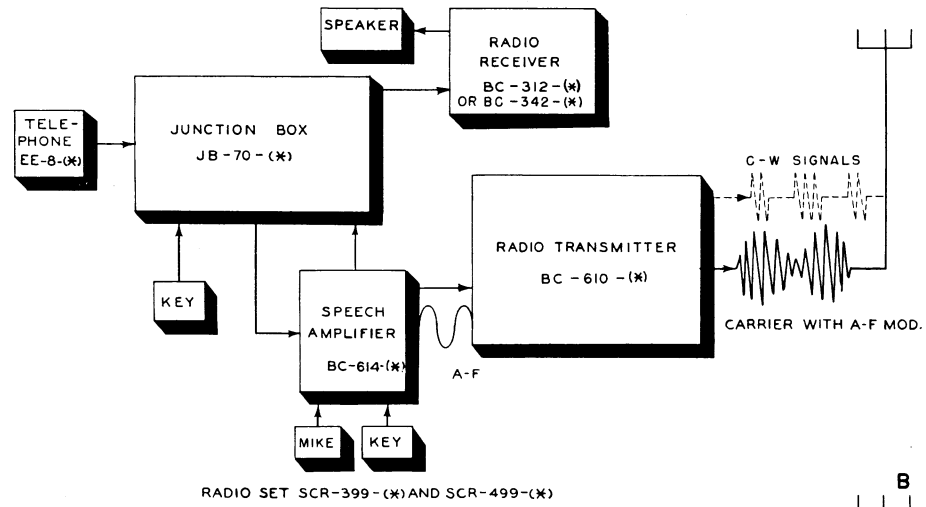

C

NOTES:

1. M AND S STAND FOR MARK AND SPACE.
2. TT STANDS FOR TELETYPEWRITER.
3. F - S STANDS FOR FREQUENCY-SHIFT.
4. C - W STANDS FOR CONTINUOUS - WAVE.

TM 5054-2

Figure 2. Simplified block diagram showing Speech Amplifier BC-614-(\*), in Radio Sets AN/GRC-26A, SCR-399-(\*), SCR-499-(\*), and AN/MRC-2(\*).

audio output level of the microphone is amplified to a level suitable to drive the input to the audio circuit in the transmitter. In addition to this, the system services provided through the speech amplifier vary with the system in which the amplifier is being used. The application of the speech amplifier in the above-mentioned systems is described briefly in *b* through *d* below.

*b. Radio Set AN/GRC-26A* (A of fig. 2).

- (1) This system is designed primarily for radio teletype communication. In this type of communication, the output frequency of the transmitter is controlled by the frequency-shift exciter in accordance with the teletypewriter intelligence being conveyed. The characteristics of frequency-shift radio teletype signals allow amplitude modulation to be placed on the carrier of Radio Transmitter BC-610-(\*). Voice may be transmitted when the output of Speech Amplifier BC-614-(\* ) is fed to the input of the modulator stage of the transmitter.
- (2) There are two microphone jacks on the speech amplifier; one is used for a carbon microphone, such as Microphone T-17, or equal, and the other is used for a dynamic (low level) microphone, such as Microphone T-50.
- (3) Two key jacks provide means for emergency c-w transmission. One jack is located on the front panel of Radio Teletypewriter Control C-808/GRC-26A, and the other is located on the front panel of Speech Amplifier BC-614-(\*). The CW KEYING jack on the radioteletype control provides the means for keying the plate power relay in the transmitter, the plate of the r-f (radio-frequency) oscillator tube, and the cathode of the buffer tube in the frequency-shift exciter. The KEY jack on the speech amplifier provides means for keying the cathode of the r-f oscillator in the transmitter.

*c. Radio Sets SCR-399-(\* ) and SCR-499-(\* ).*

Radio Sets SCR-399-(\* ) and SCR-499-(\* ) are medium-power radio communication systems. Under most atmospheric conditions and terrain, the radio set will provide voice or c-w communication over a range of more than 100 miles. In this system, the speech amplifier, in addition to raising the microphone output to a suitable level for voice modulation of the transmitter, provides

a sidetone signal for monitoring c-w keying by means of a headset. Junction Box JB-70-(\* ) serves as a control center for the station. Audio voltages from remote Telephone EE-8-(\* ) are connected to the input of the speech amplifier through the junction box. Remote c-w operation also is accomplished through Junction Box JB-70-(\* ) and Speech Amplifier BC-614-(\* ).

*d. Radio Set AN/MRC-2(\* ).*

- (1) This system is intended primarily to provide radioteletype communication in either net or long-range operation. However, the equipment is designed so that the operating features similar to those found in Radio Set SCR-399-(\* ) may be restored by disconnecting Amplifier AM-141(\* )/MRC.

*Note.*—Speech Amplifier BC-614-(\* ) is not required for radioteletype operation, but is maintained for use in case the operating features just mentioned are desired.

- (2) Emergency c-w communication (using Radio Transmitter BC-610-(\* ) and Amplifier AM-141(\* )/MRC), with a power output of 2 kw (kilowatts), is possible from Speech Amplifier BC-614-(\* ) or Junction Box JB-70-(\* ).
- (3) Junction Box JB-70-(\* ) is used to distribute power to the transmitting shelter components and to connect a monitoring headset and a telegraph key if desired.

*Note.*—For further information regarding the application of Speech Amplifier BC-614-(\* ) in systems discussed above, refer to the over-all technical manual of the system used.

## 5. Technical Characteristics

Frequency response:

Carbon microphone.  $\pm 3$  db (decibels) from 200 to 2,600 cps (cycles per second).

Dynamic microphone.  $\pm 3$  db from 200 to 3,500 cps.

Amplifier type..... A-f.

Type of input signals... Voice.

Number of tubes..... 8.

Inputs..... Carbon microphone, dynamic microphone, and external telephone.

Output..... 500 ohms, single-ended.

Power output..... Approximately 2 watts.

Power supply..... 115 volts, 50/60 cps  
 from Radio Transmitter BC-610-(\*).  
 Special features..... Modulation level meter,  
 sidetone output, external connections for  
 emergency c-w keying, external connection  
 for remote control.  
 Weight..... 31 pounds.

### 6. Packaging Data

a. Packaging data relevant to Speech Amplifier BC-614-(\*), are contained in the over-all systems manuals for Radio Sets SCR-399-(\*), SCR-499-(\*), AN/MCR-2-(\*), and AN/GRC-26A. For information concerning the packaging

of the speech amplifier in any of the above-mentioned systems, refer to the appropriate technical manual. The speech amplifier normally is not packaged when used as part of these systems. It is secured in the shelter in the normal operating position, and the connecting cables are installed.

b. When the speech amplifier is shipped separately, it may be packaged as shown in figure 4.

### 7. Description of Speech Amplifiers BC-614-H and -I

(fig. 3)

a. The speech amplifier is encased in a rectangular sheet-metal cabinet which is anchored to a base equipped with rubber shock absorbers. The cabinet can be removed easily from the base by loosening four hasps on its sides. All the electrical parts are attached to a panel-chassis

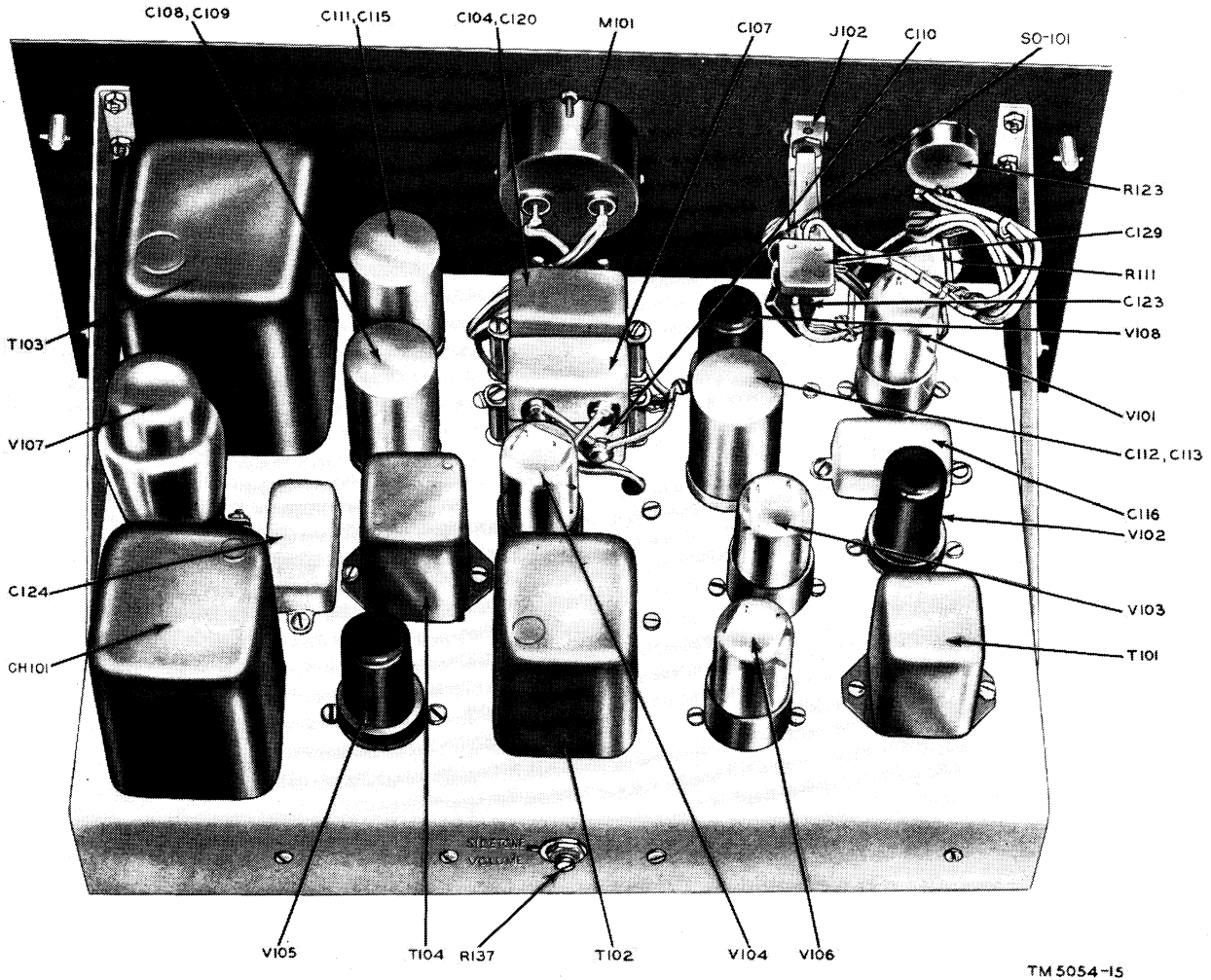

Figure 3. Speech Amplifiers BC-614-H and -I, top view of chassis.

assembly that slides out from the front of the cabinet when four winged fasteners, located in the corners of the panel, are loosened.

b. All connectors, jacks, and operating controls are located on the front panel. The tubes are accessible from the top of the chassis when the chassis is removed from the cabinet. The weight is approximately 31 pounds, unpacked.

## 8. Running Spares

Spares are provided for all normally expendable items. The following running spares are provided with each Speech Amplifier BC-614-(\*):

- 1 Lamp LM-27, .25 ampere, 6 to 8 volts.
- 1 tube type 6J5.
- 1 tube type 6SN7GT.
- 1 tube type 6SQ7.
- 1 tube type 6SR7.
- 1 tube type 80.

## 9. Additional Equipment Required

The additional equipment required for operation of Speech Amplifier BC-614-(\*) depends on the type of service to be performed. More specific information may be obtained in the over-all system technical manual of which the speech amplifier is a part. In all types of installations, it is necessary to have an a-c power source. The following equipment is required for the installation and operation of the speech amplifier.

a. A cable assembly, which connects to the socket marked TO BC-610, is used to connect the speech amplifier to the transmitter.

b. A cable assembly, which connects to the socket marked TO JB-70, is used to connect the speech amplifier to the control box.

c. Microphone T-17, T-45, or equal, which connects to the jack marked CARBON MIC. 1, is used when it is available.

d. Microphone T-50, or equal, which connects to the receptacle marked DYNAMIC MIC. 2, is used when it is available.

e. Key J-37 or J-45 with Cord 201-A, or equal, which connects to the jack marked KEY, is used when c-w transmission is desired.

## 10. Differences in Models

There is no appreciable difference in over-all operation of the various models of Speech Amplifier BC-614-(\*).

a. *Mechanical Differences.* The receiver disabling switches, the transmitter control switch, and the sidetone switch for Speech Amplifiers BC-614-E, -H, and -I, are located on Junction Box JB-70-A. The receiver disabling switches, the transmitter control switch, and the sidetone switch are installed on the panel of Speech Amplifier BC-614-F.

b. *Electrical Differences.*

- (1) In Speech Amplifiers BC-614-E, -H, and -I, voltages from the speech circuits enter the speech amplifier through terminal No. 3 of connector SO-102. In Speech Amplifier BC-614-F, these voltages enter through terminal No. 5 of connector SO-103.
- (2) Speech Amplifiers BC-614-H and -I have added resistors R145 (220,000 ohms) and R146 (6,800 ohms). These resistors are located between the high-voltage output lead and ground. They form a dividing network which prevents conduction between the heater and the cathode of tube V101. This results in a reduction in hum in the output of the amplifier.
- (3) Speech Amplifiers BC-614-E, -H, and -I contain tube V108 (6J5), used as a sidetone buffer. In Speech Amplifier BC-614-F, tube V108 is eliminated.

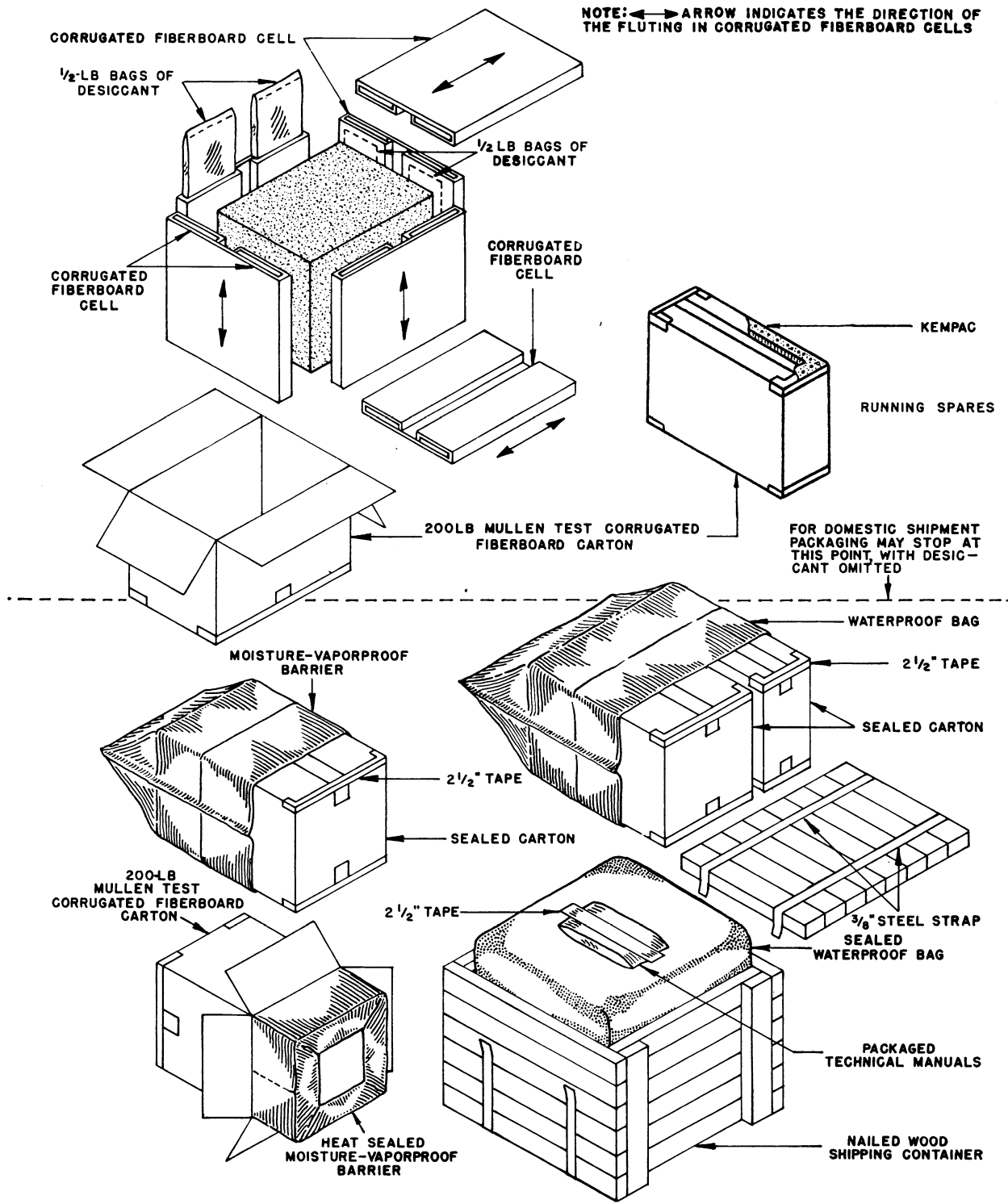

TM 5054-3

Figure 4. Speech Amplifier BC-614-(\*), typical packaging diagram.

## CHAPTER 2

# OPERATING INSTRUCTIONS

### Section I. SERVICE UPON RECEIPT OF SPEECH AMPLIFIER BC-614-(\*)

#### 11. Siting

The best location for the speech amplifier depends on the system with which it is being used. The speech amplifier should be located close to the transmitter and the associated components so that the interconnecting cables will reach the equipment. Any siting problems can be solved by referring to the appropriate technical manuals.

#### 12. Uncrating, Unpacking, and Checking New Equipment

*Note.* For used or reconditioned equipment, refer to paragraph 15.

*a. General.* Equipment may be shipped in oversea or domestic packing cases. When the equipment is received, select a location where it may be unpacked without exposure to the elements and which is convenient to the permanent installation.

**Caution:** Be careful in uncrating, unpacking, and handling the equipment; it is damaged easily. If it becomes damaged or exposed, a complete overhaul might be required, or the equipment might be rendered useless.

*b. Step-By-Step Instructions for Uncrating and Unpacking Export Shipments (fig. 4).*

- (1) Place the packing case as near the operating position as convenient.
- (2) Cut and fold back the steel straps.
- (3) Remove the nails with a nail puller. Remove the top and sides of the packing case. Do not attempt to pry off the sides and top, because the equipment may be damaged.
- (4) Open the cartons and remove the waterproof or moistureproof barrier, pads of corrugated fiberboard, and the bags of desiccant.
- (5) Remove and inspect the equipment for

possible damage incurred during shipment.

- (6) Check the contents of the packing case against the master packing slip.

*Note.* Save the original packing cases. They may be used again when the equipment is repacked for storage or shipment.

#### 13. Installation

*a.* Locate the speech amplifier according to the requirements given in paragraph 11.

*b.* Remove the panel-chassis assembly (par. 7) and see that the tubes are seated firmly in their proper sockets. Refer to figure 5 for the tube locations on the speech amplifier chassis.

#### 14. Connections

The connections to Speech Amplifier BC-614-(\* are shown in figure 6. This figure shows all the connections to the speech amplifier when it is used in any system. For further information concerning connections to the speech amplifier in any one system, refer to the appropriate over-all system technical manual.

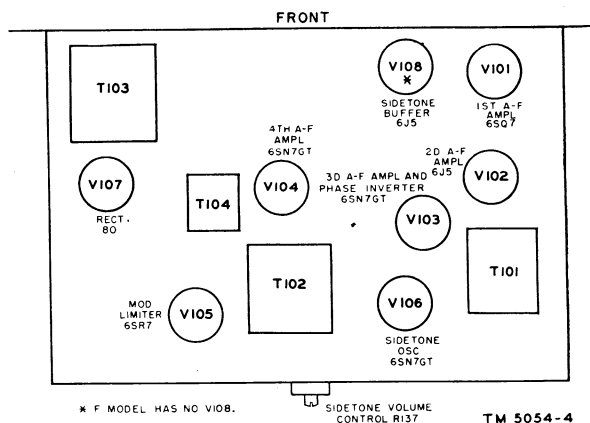
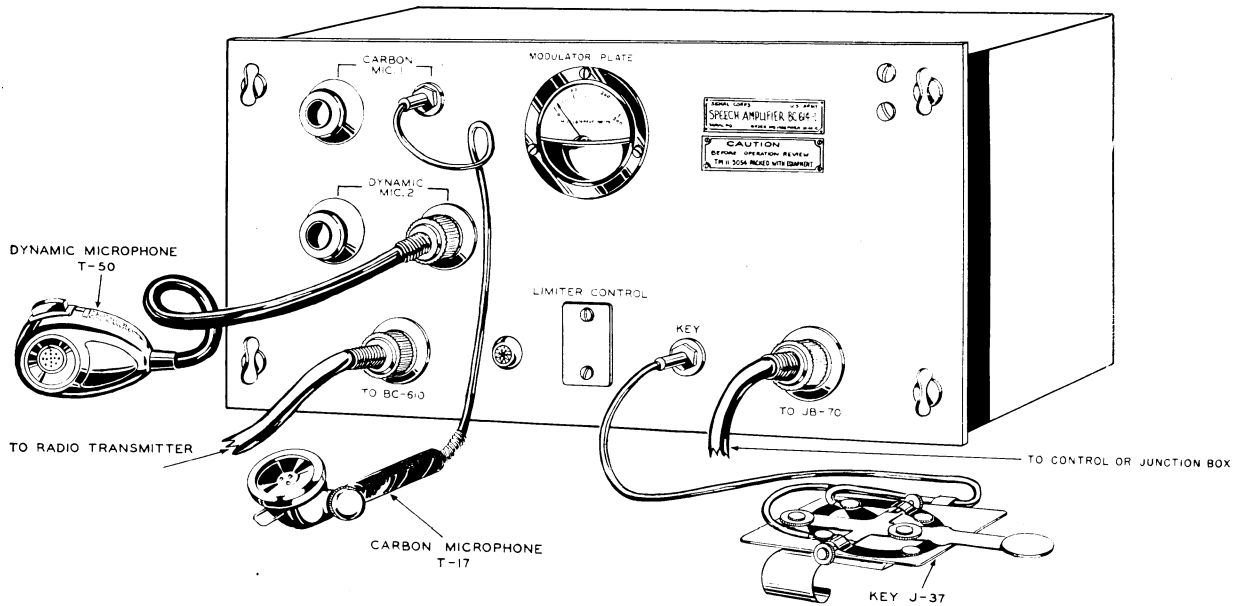

Figure 5. Speech Amplifier BC-614-(\*), tube location.



TM 5054-5

Figure 6. Speech Amplifier BC-614-(\*), connections.

### 15. Service Upon Receipt of Used or Reconditioned Equipment

- a. Follow the instructions in paragraph 12 for uncrating, unpacking, and checking new equipment.
- b. Check the used or reconditioned equipment for tags or other indications pertaining to changes

in the wiring of the equipment. If any changes in wiring have been made, note the change in this manual, preferably on the schematic diagram.

c. Check the operating controls for ease of rotation.

d. Perform the installation and connection procedures given in paragraphs 13 and 14.

## Section II. CONTROLS AND INSTRUMENTS

### 16. General

Haphazard operation or improper setting of the controls can cause damage to electronic equipment. For this reason, it is important to know the function of every control.

### 17. Speech Amplifier BC-614-(\*), Controls (fig. 7)

The following table lists the controls of the speech amplifier and indicates their functions:

Control	Function
CARBON MIC. 1 (control R123) <sup>1</sup> -----	This control adjusts the input level to the second a-f amplifier stage from the carbon microphone.
CARBON MIC. 1 (jack J102)-----	This jack connects the carbon microphone to the speech amplifier.
DYNAMIC MIC. 2 (control R111)-----	This control adjusts the input level to the first a-f amplifier stage from the dynamic microphone or from a telephone used in a remote position.
DYNAMIC MIC. 2 (Socket SO-101)-----	This socket connects the dynamic microphone to the speech amplifier.
MODULATOR PLATE meter (M101)-----	This meter indicates the current in the ground return circuit of the modulator tubes in the transmitter. The amount of current flowing, as indicated by the meter, is controlled by the adjustment of the MODULATOR BIAS control on the transmitter panel and by adjustment of either CARBON MIC. 1 or DYNAMIC MIC. 2 gain control on the speech amplifier panel.



Control	Function
Pilot lamp (red) (LM101)-----	This lamp indicates when a-c power is supplied to the speech amplifier. Power normally is supplied by Radio Transmitter BC-610-(*), and the lamp will light when the transmitter FILAMENT POWER switch is in the on (up) position.
KEY (jack J101)-----	This jack makes it possible to key the transmitter from the speech amplifier.
LIMITER CONTROL (R134)-----	This concealed control, located behind the removable plate on the front panel, adjusts the excitation voltage to the modulation limiter tube.
TO BC-610 (Connector SO-103)-----	One end of the connecting cable between the speech amplifier and the transmitter connects to this socket.
TO JB-70 (Connector SO-102)-----	One end of the connecting cable between the speech amplifier and the control unit connects to this socket.
SIDETONE VOLUME control <sup>2</sup> (R137)----	This control adjusts the output level of the sidetone buffer. It is located at the rear of the chassis.

<sup>1</sup> CARBON MIC. 1 (control R142) in BC-614-F.

<sup>2</sup> This control does not exist in BC-614-F.

### Section III. OPERATION UNDER USUAL CONDITIONS

#### 18. Starting Procedure

When Speech Amplifier BC-614-(\*) is used with Radio Transmitter BC-610-(\*), set the FILAMENT POWER switch on the transmitter front panel to the on (up) position. Power is applied to the speech amplifier by means of two conductors of the interconnecting cable connected to the socket marked TO BC-610.

#### 19. Types of Operation, Speech Amplifier BC-614-(\*)

*a. C-W Operation.* Follow the starting procedure for the transmitter outlined in the technical manual for the particular system with which it is used. When the transmitter is used in the AN/MRC-2(\*), refer to technical manual TM 11-624. When it is used in other systems, refer to the appropriate technical manuals. The transmitter now may be keyed for c-w operation from the KEY jack on the front panel of the speech amplifier.

*b. Phone Operation.* Follow the starting procedure for the transmitter outlined in the technical manual for the particular system with which it is used. When the transmitter is used in the AN/MRC-2(\*), refer to TM 11-624. When it is used in other systems, refer to the appropriate technical manuals. When Radio Transmitter BC-610-(\*), or equal, is tuned for either crystal or master-oscillator-controlled operation, perform the following steps:

- (1) Set the MODULATOR BIAS control on the transmitter to the extreme counter-

clockwise (zero) position. (This increases the bias.)

- (2) Set the C. W.-PHONE switch on the transmitter to the PHONE position.

**Caution:** Never operate this switch while the PLATE POWER switch on the transmitter is on (red lamp lit).

- (3) Set the PLATE POWER switch to the on position. This closes plate power relay RY1 and opens antenna shorting relay RY4 in the transmitter. The P. A. PLATE meter should read approximately 250 ma (milliamperes), which is the normal plate current for voice operation. If the transmitter has been tuned to 290 ma on c-w operation, the plate current will be 250 ma when the transmitter is switched to voice, because changing the C. W.-PHONE switch to PHONE automatically reduces the power-amplifier plate voltage. If the P. A. PLATE meter indicates more than 260 ma, turn off the plate power and adjust the transmitter antenna coupling coil until the plate current is reduced to the proper value.
- (4) Adjust the MODULATOR BIAS control on the transmitter for 40 ma of modulator current, with no audio input to the transmitter. This is indicated on the MODULATOR PLATE meter on the speech amplifier.
- (5) Adjust the microphone gain control on the speech amplifier until the output of

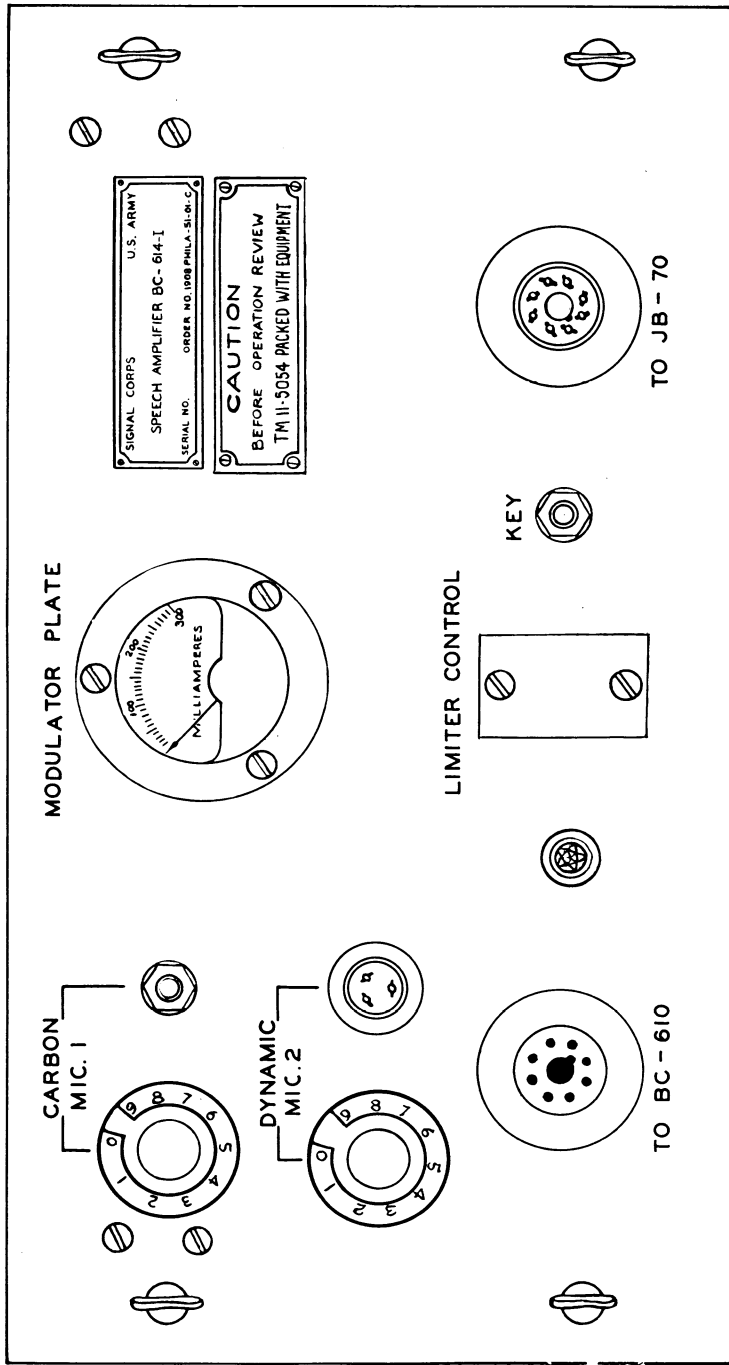

TM 5054-6

Figure 7. Speech Amplifier BC-614 (\*), front view, showing controls.

the speech amplifier causes the MODULATOR PLATE meter to indicate 200 ma at voice peaks. This completes the tuning procedure. The transmitter and speech amplifier are ready for voice operation.

## 20. Stopping Procedure

When Radio Transmitter BC-610-(\*), or equal, is used, follow the stopping procedure of the

transmitter in the technical manual for the transmitter. When this transmitter is to be turned off, perform the following functions:

- a. Set the EXCITER PLATE POWER switch to NORMAL.
- b. Set the PLATE POWER switch to the off (down) position.
- c. Set the FILAMENT POWER switch to the off (down) position. This switch turns the speech amplifier off.

## Section IV. OPERATION UNDER UNUSUAL CONDITIONS

### 21. General

The operation of Speech Amplifier BC-614-(\*) may be difficult in regions where extreme cold, heat, humidity and moisture, sand conditions, etc., prevail. In paragraphs 22 through 24, instructions are given on procedures for minimizing the effect of these unusual operating conditions.

### 22. Operation in Arctic Climates

Subzero temperatures and climatic conditions associated with cold weather affect the efficient operation of the equipment. Instructions and precautions for operation under such adverse conditions follow.

- a. Handle the equipment carefully.
- b. Keep the equipment warm and dry.
- c. Heavy coatings of frost will gather on mouth-type microphones in extreme cold weather when the microphones are used in the open air or in a cold room. Frost will form from the breath in the small holes of the cap and will affect transmitter modulation. Rubber diaphragms have been designed to protect some types of microphones; use them when available. Have a spare microphone ready, if possible, in case the one in use fails to function properly.
- d. When equipment which has been exposed to the cold is brought into a warm room, it will start to sweat and will continue to do so until it reaches room temperature. When the equipment has reached room temperature, dry it thoroughly. This condition also arises when equipment warms up during the day after exposure during a cold night.

### 23. Operation in Tropical Climates

When operated in tropical climates, the equipment may be installed in tents, huts, or, when

necessary, in underground dugouts. When equipment is installed below ground or when it is set up in swampy areas in tropical regions, moisture conditions are more acute than normal. Ventilation usually is very poor, and the high relative humidity causes condensation of moisture on the equipment whenever the temperature of the equipment becomes lower than the ambient air. To minimize this condition, place lighted electric bulbs under the equipment.

### 24. Operation in Desert Climates

- a. Conditions similar to those encountered in tropical climates often prevail in desert areas. Use the same measures to insure proper operation of the equipment.
- b. The main problem that arises with equipment operation in desert areas is the large amount of sand or dust and dirt that enters the moving parts of radio equipment. The ideal preventive precaution is to house the equipment in a dust-proof shelter. Since such a building is seldom available and would require air conditioning, the next best precaution is to make the building in which the equipment is located as dustproof as possible with available materials. Hang wet sack- ing over the windows and doors, cover the inside walls with heavy paper, and secure the side walls of tents with sand to prevent their flapping in the wind.
- c. Never tie power cords, signal cords, or other wiring connections to either the inside or the outside of tents. Desert areas are subject to sudden wind squalls which may jerk the connections loose or break the lines.
- d. Take care to keep the equipment as free from dust as possible. Make frequent preventive maintenance checks (par. 28).

## CHAPTER 3

### PREVENTIVE MAINTENANCE INSTRUCTIONS

---

#### Section I. PREVENTIVE MAINTENANCE SERVICES

##### 25. Definition of Preventive Maintenance

Preventive maintenance is work performed on equipment (usually when the equipment is not in use) to keep it in good working order so that breakdowns and needless interruptions in service will be kept to a minimum. Preventive maintenance differs from trouble shooting and repair since its object is to prevent certain troubles from occurring. See AR 750-5.

##### 26. General Preventive Maintenance Techniques

- a. Use No. 0000 sandpaper to remove corrosion.
- b. Use a clean, dry, lint-free cloth or a dry brush for cleaning.
  - (1) If necessary, except for electrical contacts, moisten the cloth or brush with Solvent, dry-cleaning (SD); then wipe the parts dry with a cloth.
  - (2) Clean electrical contacts with a cloth moistened with carbon tetrachloride; then wipe them with a dry cloth.

**Caution:** Repeated contact of carbon tetrachloride with the skin or prolonged breathing of the fumes is dangerous. Make sure adequate ventilation is provided.

c. If available, dry compressed air may be used at a line pressure not exceeding 60 pounds per square inch to remove dust from inaccessible

places; be careful, however, or mechanical damage from the air blast may result.

d. For further information on preventive maintenance techniques, refer to TB SIG 178.

##### 27. Use of Preventive Maintenance Forms

a. The information in paragraph 28 is presented as a guide to the individual making an inspection of equipment in accordance with instructions on DA AGO Forms 11-238 and 11-239. The decision as to which items on the forms are applicable to this equipment is a tactical decision to be made in the case of first echelon maintenance by the communication officer/chief or his designated representative, and in the case of the second and third echelon maintenance by the individual making the inspection. Instructions for the use of each form appear on the reverse side of the form.

b. The first two columns in the table in paragraph 28 serve as a cross reference between the item numbers of DA AGO Forms 11-238 and 11-239 and the preventive maintenance information in this manual.

##### 28. Performing Preventive Maintenance

Perform the following preventive maintenance operations at the intervals indicated unless these intervals are reduced by the local commander.

**Caution:** Tighten screws, bolts, and nuts carefully. Fittings tightened beyond the pressure for which they are designed will be damaged or broken.

DAILY

- |   |   |   |
|---|---|---|
| 1 | 1 | Check for completeness and satisfactory condition of equipment, including all spare parts and the technical manual (par. 12b(5) and (6)). |
| 2 | 2 | Check for suitability of location and installation for normal operation (par. 11).  |
| 3 | 3 | Clean dirt and moisture from jacks, plugs, and front panel components (fig. 1).   |
| 4 | 4 | Inspect seating of readily accessible <i>pluck-out</i> items: tubes, lamps, and connectors (fig. 3).                                      |
| 5 | 5 | Inspect controls for binding, scraping, excessive looseness, and positive action (par. 15c).  |
| 6 | 6 | Check for normal operation.   |

WEEKLY

- |    |    |   |
|----|----|---|
| 7  | 7  | Remove the speech amplifier from its cabinet and clean the interior of the cabinet and the exterior of the chassis (fig. 3).  |
| 8  | 8  | Inspect the case for signs of corrosion.  |
| 9  | 9  | Inspect cord, cable, and wires for cuts, fraying, kinks, and strain (par. 14 and fig. 6).                                     |
| 12 | 12 | Inspect for looseness of accessible items: switches, knobs, jacks, connectors, capacitors, and pilot light assembly (fig. 3). |
| 14 | 14 | Clean the meter window (fig. 1).  |
| 15 | 15 | Inspect meter for damaged glass and case (fig. 1).  |

MONTHLY

- |    |    |  |
|----|----|--|
| 19 | 19 | Inspect electron tubes for loose envelopes and cracked bases; clean and dust carefully.      |
| 21 | 21 | Inspect capacitors for leaks and bulges.   |
| 24 | 24 | Inspect resistors and insulators for cracks, blistering, discoloration, and moisture.        |
| 25 | 25 | Inspect terminals of capacitors and resistors for corrosion, dirt, and loose contacts.       |
| 26 | 26 | Clean and tighten all switches and knobs.  |
| 31 | 31 | Clean and tighten connections and mountings for transformers, resistors, and potentiometers. |
| 32 | 32 | Inspect transformers and potentiometers for overheating.                                     |
| 37 | 37 | Moistureproof and fungiproof (par. 29b).   |
| 38 | 38 | If deficiencies noted are not corrected during inspection, indicate what action was taken.   |

## Section II. WEATHERPROOFING AND LUBRICATION

### 29. Weatherproofing and Lubrication

*a. General.* Signal Corps equipment, when operated under severe climatic conditions such as prevail in tropical, arctic, and desert regions, requires special treatment and maintenance. Fungus growth, insects, dust, corrosion, salt spray, excessive moisture, and extreme temperatures are harmful to most materials.

*b. Tropical Maintenance.* A special moistureproofing and fungiproofing treatment has been devised which, if properly applied, provides a reasonable degree of protection. This treatment is explained in TB SIG 13 and TB SIG 72. Moistureproofing and fungiproofing are necessary only when parts are replaced, since the equipment is given this treatment at the factory.

*c. Winter Maintenance.* Special precautions necessary to prevent poor performance or total operational failure of equipment in extremely low temperatures are explained in TB SIG 66 and TB SIG 219.

*d. Desert Maintenance.* Special precautions necessary to prevent equipment failure in areas

subject to extremely high temperatures, low humidity, and excessive sand and dust are explained in TB SIG 75.

*e. Lubrication.* No lubrication is required for Speech Amplifier BC-614-(\*).

### 30. Rustproofing and Painting

*a.* When the finish on the case has been badly scarred or damaged, rust and corrosion can be prevented by touching up bared surfaces. Use No. 00 or No. 000 sandpaper to clean the surface down to the bare metal; obtain a bright smooth finish.

**Caution:** Do not use steel wool. Minute particles frequently enter the case and cause harmful internal shorting or grounding of circuits.

*b.* When a touch-up job is necessary, apply paint with a small brush. Remove rust from the case by cleaning corroded metal with solvent (SD). In severe cases it may be necessary to use solvent (SD) to soften the rust and to use sandpaper to complete the preparation for painting. Paint used will be authorized and consistent with existing regulations.

## CHAPTER 4

### THEORY

#### 31. Block Diagram

(fig. 8)

Speech Amplifier BC-614-(\*) is an a-f amplifier, designed for use with Radio Transmitter BC-610-(\*) or similar transmitters. The basic purpose of the speech amplifier is to raise a microphone output to a level which is suitable to drive the input of the audio circuit in the transmitter. The speech amplifier also provides sidetone for headset monitoring of outgoing c-w transmission.

*a. First A-F Amplifier.* The a-f voltage from a dynamic microphone (Microphone T-50, or equal) or Telephone EE-8-(\*) enters the first a-f amplifier V101 through connector SO-101 marked DYNAMIC MIC. 2 and an attenuating network which presents the correct impedance. The audio voltage is amplified by tube V101 and is coupled to the second a-f amplifier stage.

*b. Second A-F Amplifier.* The output from tube V101 is fed to the second voltage amplifier, V102. When the carbon microphone (Microphone T-17 or T-45) is in use, the input voltage is fed through jack J102 marked CARBON MIC. 1 to the input of V102. The amplified a-f voltages which appear in the plate circuit of V102 are fed to twin-triode tube V103.

*c. Third A-F Amplifier and Phase Inverter.* The third audio-amplifier and phase-inverter tube, V103, further amplifies the a-f voltages in one section and provides a push-pull output to the grids of tube V104 in the other section.

*d. Fourth A-F Amplifier.* Twin-triode tube V104 operates as a push-pull amplifier. The output from this tube is connected through a transformer to a low-impedance unbalanced line through which the amplified a-f voltages are fed to the transmitter.

*e. Modulation Limiter.* A portion of the voltage on one of the grids (pin 4) of V104 is fed to the grid of tube V105 which is a modulation limiter. The output of tube V105 is applied as a

variable bias voltage to the grid of tube V102. The amplification factor of tube V102, as used in this application, varies in accordance with the grid bias variations.

*f. Sidetone Oscillator.* Tube V106 is a twin-triode audio oscillator connected in a multivibrator circuit and is used to generate a sidetone signal for monitoring outgoing c-w transmissions. When the transmitter is keyed, the cathode circuit of tube V106 is completed to ground through the control box in the system used. Sidetone buffer tube V108 couples the output of tube V106 to the headphones and provides the sidetone signal. Buffer tube V108 does not appear in Speech Amplifier BC-614-F.

*g. Power Supply.* A-c power is supplied to the speech amplifier from the transmitter through connector SO-103 marked TO BC-610. This a-c voltage is stepped up by the h-v (high-voltage) secondary winding and rectified by rectifier V107 which, in turn, supplies plate and screen voltages for the speech amplifier. There are two l-v (low-voltage) secondary windings that furnish the filament voltages for all the tubes in the speech amplifier.

#### 32. First A-F Amplifier

(fig. 9)

The first a-f amplifier uses a 6SQ7 tube (V101) to amplify the output of a dynamic microphone or remote telephone. The tube is connected as a triode (by connecting the diode plates to ground) in a class A amplifier stage.

*a.* The tube is self-biased as a result of the d-c (direct-current) voltage drop across cathode bias resistor R106. R106 is unbypassed to produce degeneration which improves the frequency response and reduces distortion in the amplifier. Plate voltage is furnished by the power supply in the speech amplifier and is applied to the plate of tube V101 through decoupling resistors R126, R127, and R128 and load resistor R107. Resistor

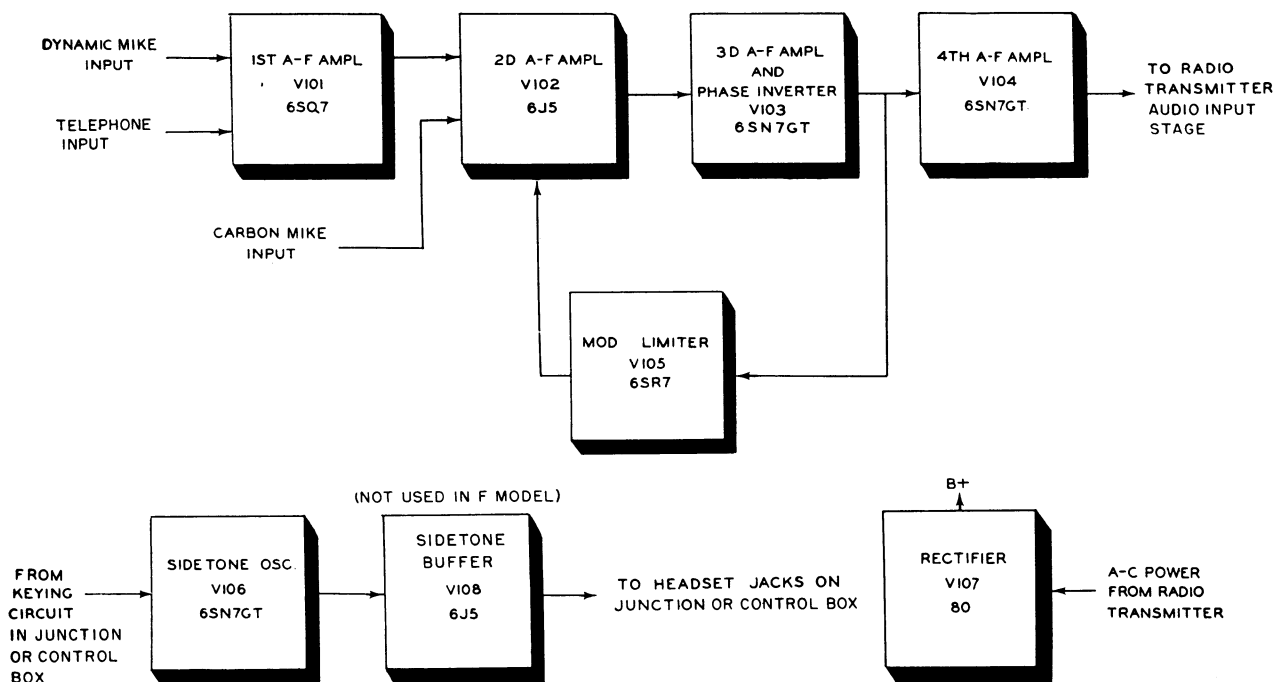

TM 5054-7

Figure 8. Speech Amplifier BC-614-(\*), block diagram.

R128 and capacitor C113 form the plate circuit decoupling network which prevents feedback from succeeding stages through the common impedance of the power supply. Capacitor C124 prevents sparking across the microphone switch contacts, and C123 acts as an r-f bypass in the switching circuit.

b. The network in the grid circuit, consisting of resistors R101 through R105, is designed to match properly the impedance of a dynamic microphone and a telephone line. The dynamic microphone, such as Microphone T-50, requires a high-impedance input; Telephone EE-8-(\*) requires a low-impedance input. In addition to matching impedance, the network also provides the correct attenuation of the input a-f voltage; this is necessary because the output voltage levels of the dynamic microphone and the telephone differ considerably. When Microphone T-50 is used, the microphone output voltage is attenuated approximately 30 db; when Telephone EE-8-(\*) is used, the attenuation is approximately 50 db. C130 is an r-f bypass capacitor to prevent h-f (high-frequency) interference from affecting the amplifier when the input is connected to a telephone line. Capacitor C127 places the filament at r-f ground potential.

c. The amplified voltage of tube V101 is devel-

oped across R107 and is resistance-capacitance coupled to the grid of the second a-f amplifier through audio-coupling capacitors C102 and C119, resistor R108, and potentiometer R111.

### 33. Second A-F Amplifier

(fig. 9)

The second a-f amplifier uses triode tube 6J5 (V102) to amplify the output of the first a-f amplifier or of a carbon microphone. The output of the carbon microphone such as Microphone T-17 is fed into the second a-f amplifier tube because the output level of the carbon microphone is considerably higher than that of the dynamic microphone.

a. Bias voltage is provided partly by the modulation limiter and partly from the self-biasing action of resistor R112 in the cathode circuit. The action of the modulation limiter is described in paragraph 36. R112 is unbypassed to introduce degeneration. Plate voltage is applied through decoupling resistors R126 and R127 and load resistor R113. Resistor R127 and capacitor C112 form the plate circuit decoupling network.

b. When a dynamic microphone or telephone is used, the output voltage of the first a-f stage is coupled through capacitor C102 and resistor

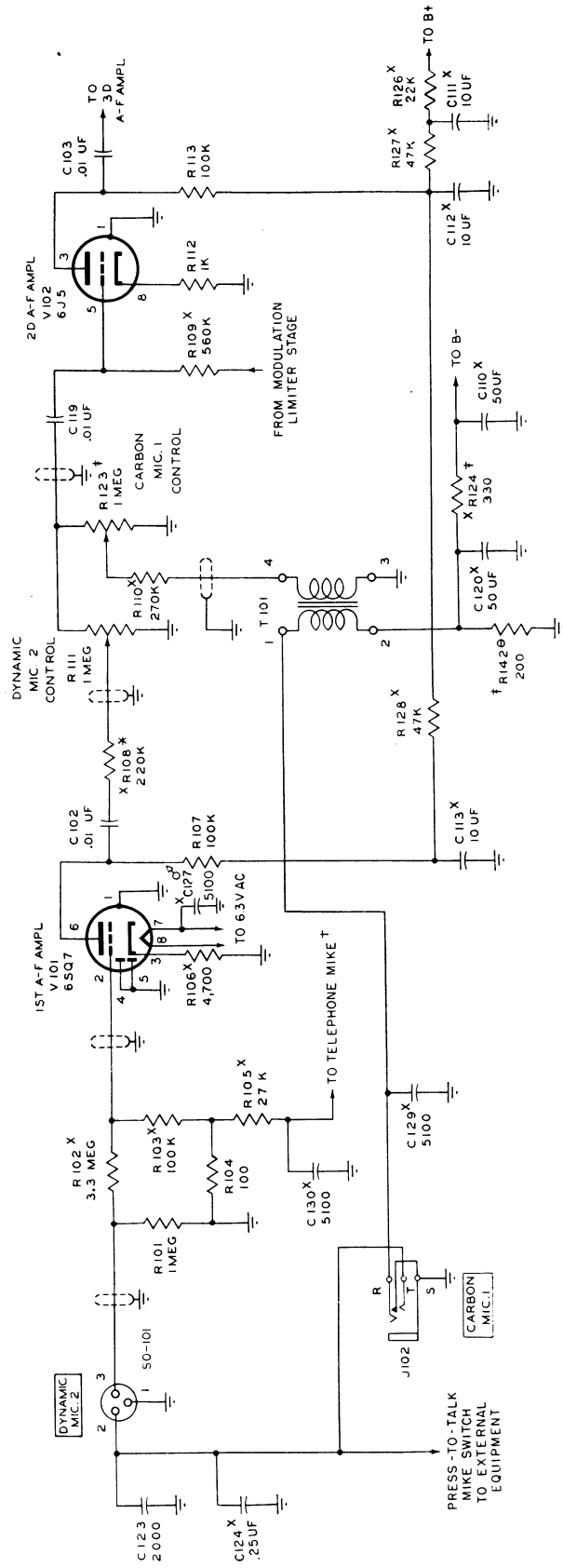

NOTES:

1. UNLESS OTHERWISE SHOWN, RESISTORS ARE IN OHMS, CAPACITORS ARE IN UUF.
  2. \* R108 IS OMITTED IN SOME E MODELS.
  3. † IN THE F MODEL, THIS LEAD GOES TO SWITCH SW105B.
  4. ‡ IN THE F MODEL, R124 IS R141 (WITH VALUE OF 300). R123 IS R142, AND R142 IS NOT USED.
  5. § IN THE E MODEL, C127 IS CONNECTED BETWEEN PIN 8 OF V101 AND GROUND.
  6. ¶ IN MODELS E AND H, R142 IS CONNECTED BETWEEN TERMINAL 1 OF T101 AND GROUND. ITS VALUE IN H MODEL IS 51.
  7. X COMPONENT VALUES FOR ALL MODELS ARE AS ILLUSTRATED EXCEPT AS INDICATED IN CHART.
- VALUES LISTED UNDER H MODEL APPLY ONLY TO H MODELS SERIAL NUMBERS 1 THRU 53<sup>3</sup> PROCURED ON ORDER NO. 19624-P-50. ALL OTHER H MODELS ARE IDENTICAL WITH THE I MODEL.

COMPONENT	VALUE		
	E MODEL	F MODEL	H MODEL
C110		30UF	
C120			
C111		8UF	
C113			
C124	35 UF	35 UF	35 UF
C127			
C129	5,000	NOT USED	4,700
C130			
R102	3 MEG	1 MEG	
R103		200K	
R105	25K	5K	
R106	5K	1K	
R108	200K		
R109	500K		
R110		250K	
R124			
R126		20K	
R127			
R128		50K	

Figure 9. First and Second a-f amplifier stages, schematic diagram.



R108 to the movable contact of potentiometer R111 (DYNAMIC MIC. 2 control). The portion of the signal voltage appearing across R111 is fed to the grid of V102 through C119. Capacitor C119 blocks dc from the secondary winding of the carbon microphone input transformer (T101) and reduces its loading effect on the modulation limiter output. R108 provides a more uniform load impedance for V101 as R111 is varied. This improves the l-f (low-frequency) response of the amplifier at low settings of gain control R111. DYNAMIC MIC. 2 gain control R111 controls the output of the speech amplifier when a dynamic microphone or telephone is used.

c. The signal from the carbon microphone impressed across the primary of a-f transformer T101 is amplified by the second a-f amplifier stage. The a-f voltage developed across the secondary winding of T101 is applied to the grid of V102 through resistor R110, potentiometer R123 (CARBON MIC. 1 control), and capacitor C119. CARBON MIC. 1 gain control R123 controls the output of the speech amplifier when a carbon microphone is used. Resistor R110 and potentiometer R123 serve as a termination for transformer T101. In addition, resistor R110 isolates the low-resistance secondary winding of T101 from the grid circuit of tube V102. This effectively prevents the winding from lowering the gain of the amplifier in case the gain control for

the carbon microphone is left open when a dynamic microphone or telephone is used.

d. Current for the carbon microphone is obtained from the speech-amplifier power supply and is applied to microphone resistor R124 and the primary winding of transformer T101. Resistor R142 is effectively in parallel with the carbon microphone. This limits the current through the microphone to 9.5 ma. Resistor R124 and capacitors C120 and C110 form a pi-section filter which filters all the a-c hum voltage from the current supplied to the microphone. Capacitor C129 is connected across the microphone and serves as an h-f bypass capacitor to reduce microphone hiss and r-f interference which may enter the amplifier by way of the microphone cord.

e. The output voltage of tube V102 is developed across R113 and is applied to the third a-f amplifier grid (pin 1) through audio-coupling capacitor C103.

### 34. Third A-F Amplifier and Phase Inverter

(fig. 10)

Tube V103 is connected in a self-balancing phase-inverter circuit. The tube (type 6SN7GT) contains two triode sections in the same envelope. One section functions as a conventional resistance-capacitance coupled amplifier; the other section provides the 180° phase reversal required to excite

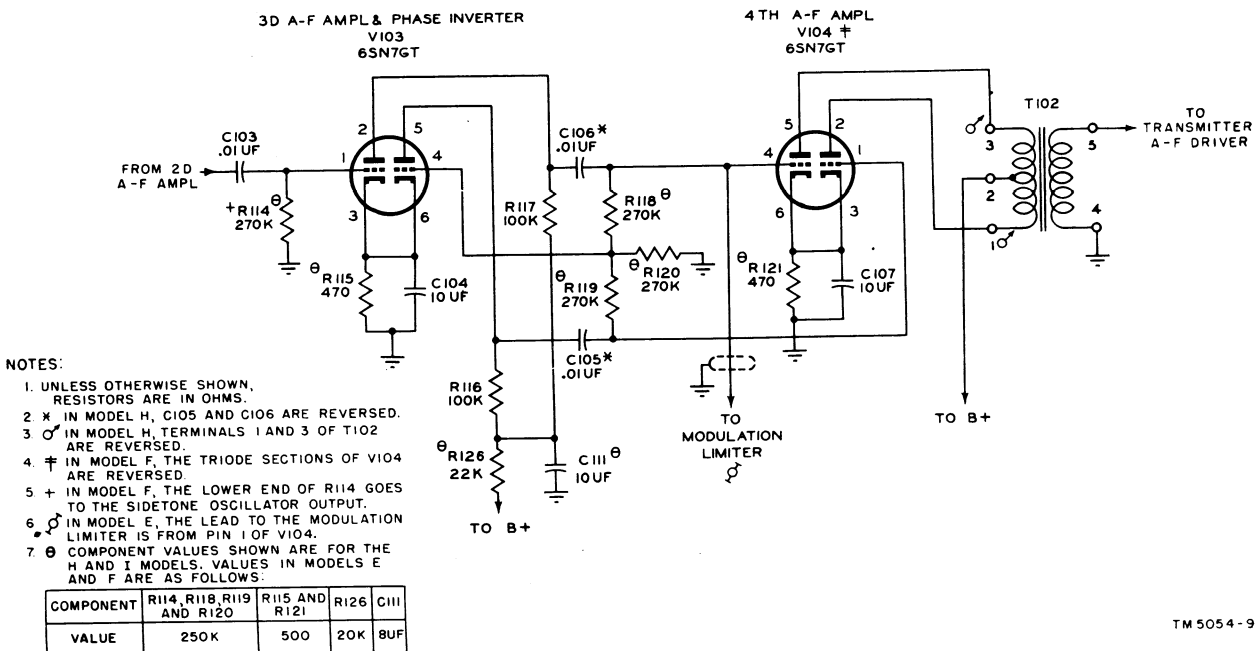

Figure 10. Third a-f amplifier, phase inverter, and fourth a-f amplifier, schematic diagram.

the second grid (pin 1) of the fourth a-f push-pull amplifier stage.

a. The tube is self-biased as a result of the d-c voltage drop across cathode-bias resistor R115. Capacitor C104 places the cathodes at a-f ground potential. Plate voltage for each section of the tube is applied through decoupling resistor R126 and plate load resistors R117 and R116, respectively. R126 and C111 form the plate circuit decoupling network.

b. The a-f signal from tube V102 is applied to the grid (pin 1) of the a-f amplifier section of twin-triode tube V103 through coupling capacitor C103. R114 is the grid d-c return resistor. The output signal from the amplifier section of tube V103 is applied to the grid of tube V104 (pin 4) through capacitor C106. This signal also appears across the series-resistance path consisting of grid resistors R118 and R120. The portion of this signal appearing across resistor R120 provides grid excitation for the phase-inverter section of tube V103. The plate circuit of this section of tube V103 provides a signal, through capacitor C105, for the grid of tube V104 (pin 1) which is opposite in polarity, at any instant, to the signal applied to the grid (pin 4) of tube V104. The signal voltage on pin 1 also appears across resistors R119 and R120. Resistors R118 and R119 are equal in value. As the signal applied to pin 4 of tube V104 becomes greater than the signal applied to pin 1, the polarity, at any instant, of the voltage developed across resistor R120 is such as to cause greater instantaneous output from the phase-inverter section of tube V103. The two grids of tube V104, therefore, are excited almost equally, and the voltage drop across resistor R120, caused by the signal applied to pin 4 of tube V104, is almost canceled by a voltage of opposite polarity and of nearly equal amplitude caused by the signal applied to pin 1 of tube V104. The remaining uncanceled voltage across resistor R120 corresponds to the unbalance between the signals applied to the two grids of tube V104. This unbalanced voltage then excites the grid of the phase-inverter section of tube V103 so that the output of the phase inverter tends to reduce the unbalance. In this manner, the self-balance is effected. The high gain of tube V103 results in a very small percentage of unbalance, even with considerable variations in the two sections of tube V103 and variations in circuit constants.

### 35. Fourth A-F Amplifier

(fig. 10)

Tube V104 (6SN7GT) is connected in a class A push-pull amplifier stage. Its purpose is to amplify the output of the third a-f amplifier stage sufficiently to excite the grids of the push-pull driver stage located in the transmitter.

a. The tube is self-biased as a result of the d-c voltage drop across cathode-biasing resistor R121 which is bypassed for audio frequencies by capacitor C107. Plate voltage is obtained from the speech-amplifier power supply and is applied to the plates of the tube through the primary-winding center tap of the push-pull output transformer T102.

b. Grid excitation for tube V104 is provided by the third a-f amplifier and phase inverter. Transformer T102 is designed to match the plate-to-plate impedance of tube V104 to a 500-ohm transmission line. The a-f output voltage appearing across the secondary winding of the output transformer is fed to the driver stage in the transmitter over a 500-ohm transmission line.

### 36. Modulation Limiter

(fig. 11)

Tube V105 (6SR7) is connected in a modulation limiter circuit. Its purpose is to produce a d-c control voltage which is used to bias the second a-f amplifier tube, in order to change the amplitude of its output with changes in the input. It acts as a nonlinear device to decrease the amplitude of the modulation on strong signals more than on weak signals. It causes *compression* of the stronger modulating signals. Tube V105 performs two functions. The triode section of the tube functions as an a-f amplifier, and the two diodes are connected in a full-wave rectifier circuit.

a. The tube is self-biased as a result of the d-c voltage developed across cathode-biasing resistor R131 which is unbypassed to introduce some degeneration. Plate voltage is applied through decoupling resistors R126, R127, and R129 and plate load resistor R130. Resistor R129 and capacitor C115 form the plate circuit decoupling network.

b. Excitation voltage for the grid of tube V105 is obtained from one of the grids (pin 4) of tube V104 through R134, the modulation LIMITER CONTROL. A portion of this voltage is amplified by the triode section of the tube and coupled to the primary of transformer T104 through C114.

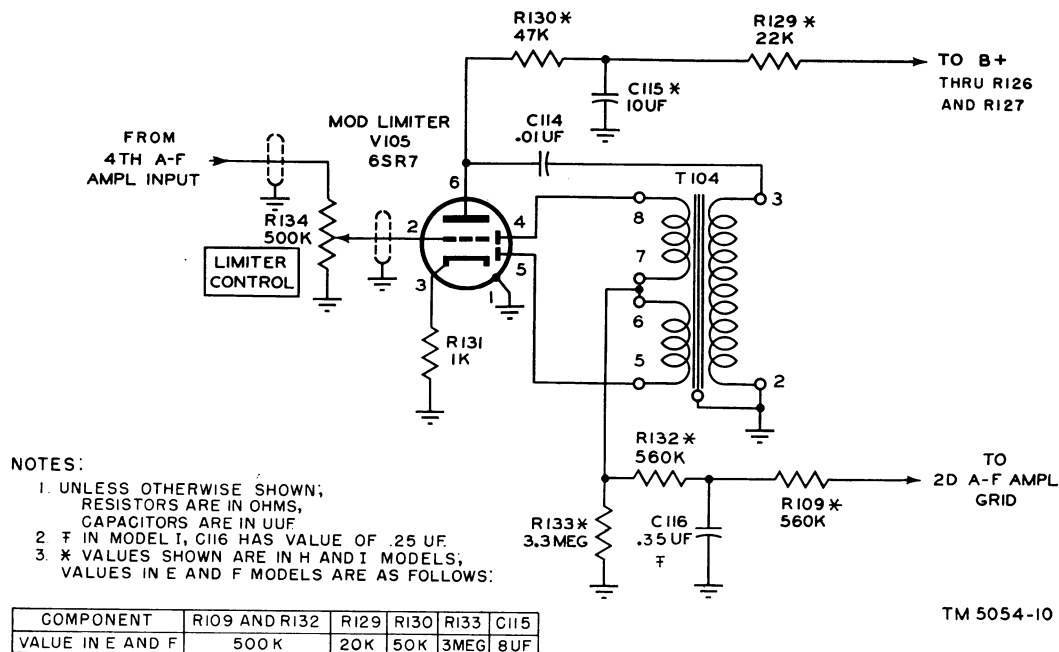

Figure 11. Modulation limiter, schematic diagram.

The center-tapped secondary of T104 is across the diode plates and a rectified a-f voltage appears across R133, which is filtered by R132 and C116. The negative d-c voltage appearing across C116 is used to control the amplification of tube V102.

c. Tube V102 is operated on the lower portion of its characteristic curve. Under this condition, the transconductance of the tube varies inversely with variations in grid bias. An increase in grid bias decreases the transconductance, and vice versa. When LIMITER CONTROL R134 has been adjusted properly, the modulation limiter provides a minimum of 3-db compression at 100 percent modulation; this has the effect of raising the average modulation level approximately 7 db without exceeding 100 percent modulation on voice peaks. For the adjustment procedure for the LIMITER CONTROL, refer to paragraph 51.

### 37. Sidetone Oscillator

(fig. 12)

The purpose of the sidetone oscillator is to generate a sidetone signal required for monitoring the outgoing c-w transmission.

a. Tube V106 (6SN7GT) is a dual-triode tube connected in a multivibrator circuit. The multivibrator circuit is essentially a two-stage, resistance-coupled amplifier in which the voltage devel-

oped by the output of the second triode is fed back to the input of the first triode.

b. The cathode circuit is completed to ground through the external equipment used with the speech amplifier. Tube V106 is self-biased by the d-c voltage drop across cathode-biasing resistor R136. Capacitor C128 is the a-f bypass capacitor for resistor R136. Plate voltage is applied to pins No. 5 and 2 of V106 through load resistors R139 and R140, respectively.

c. Plate current flow through the first triode section of tube V106 (models E, H, and I) causes a voltage drop across plate load resistor R139. The reduced voltage at the plate (pin No. 5) is applied to the grid (pin No. 1) of the second triode section through capacitor C118; this produces a corresponding change in plate current. Lower plate current causes a lower voltage drop across plate load resistor R140; this increases the voltage at pin No. 2. The increased voltage is coupled through C117 to the grid (pin No. 4), which further increases the current in the first triode. When the second section is cut off, there is no further change in current flow through the capacitors and they discharge; this reverses the process. Resistor R135 is the grid resistor for the first section. Resistor R138 in series with SIDETONE VOLUME control R137 form the grid resistor for the second section. The oscillation frequency is determined

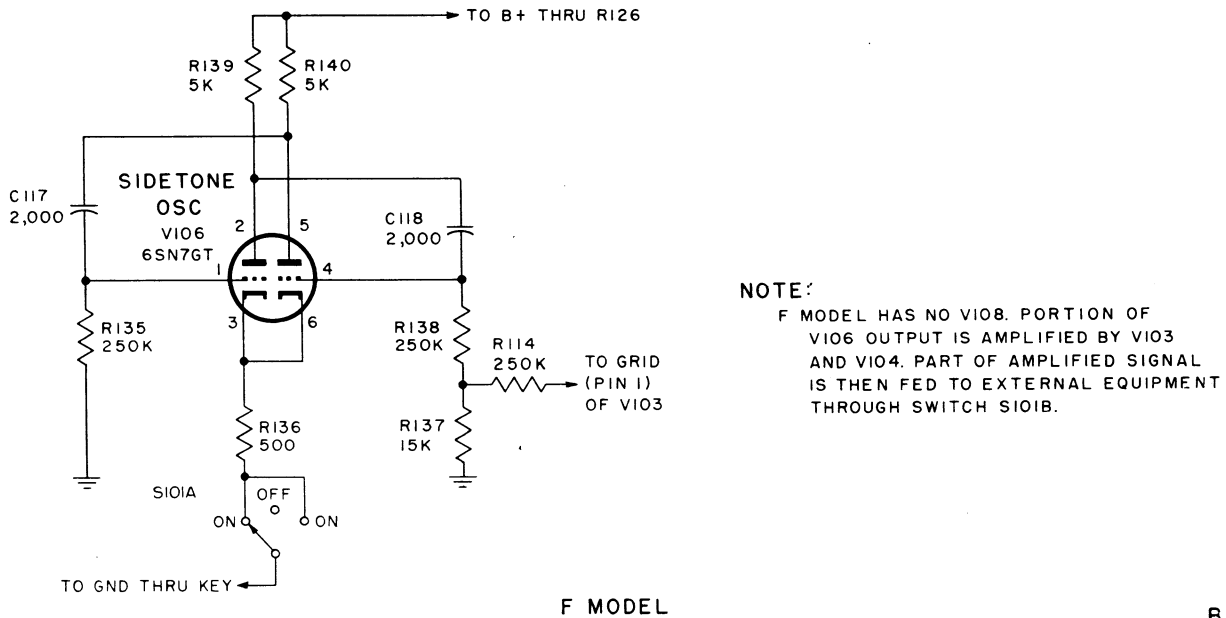
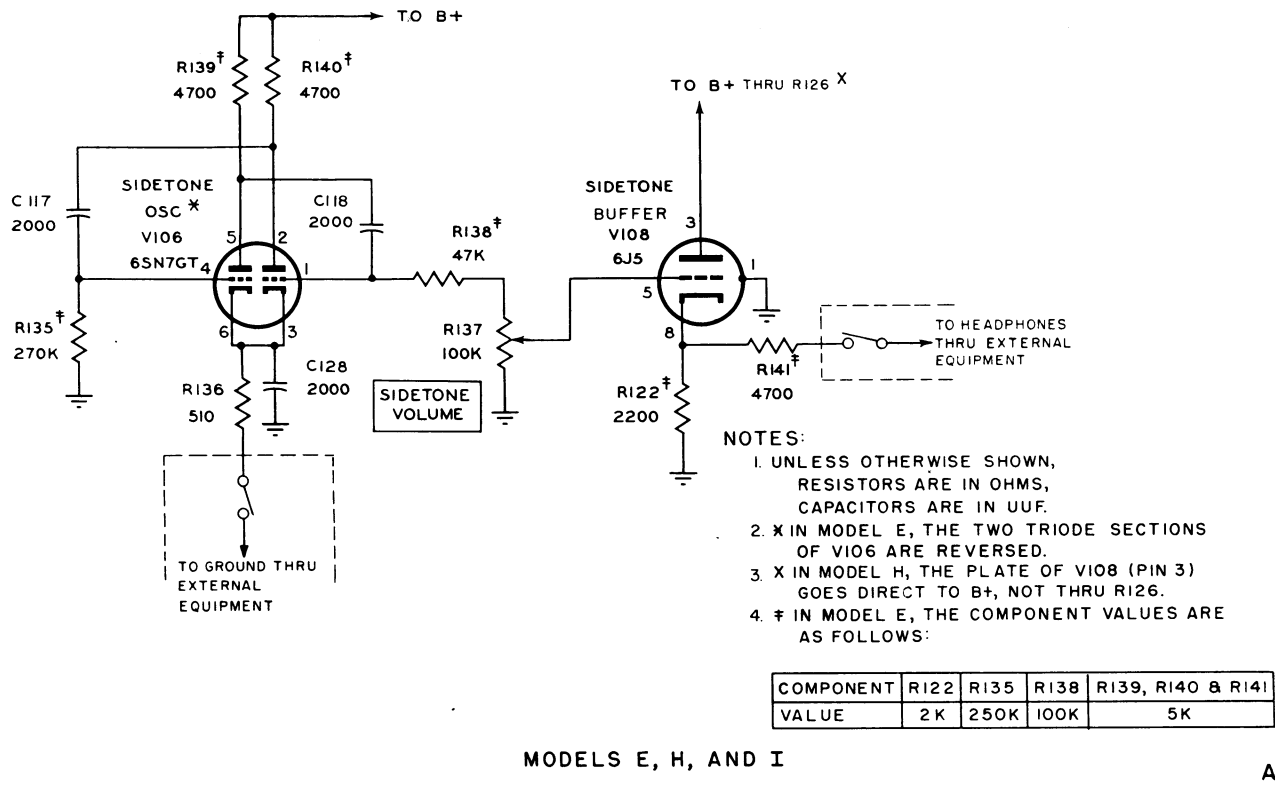
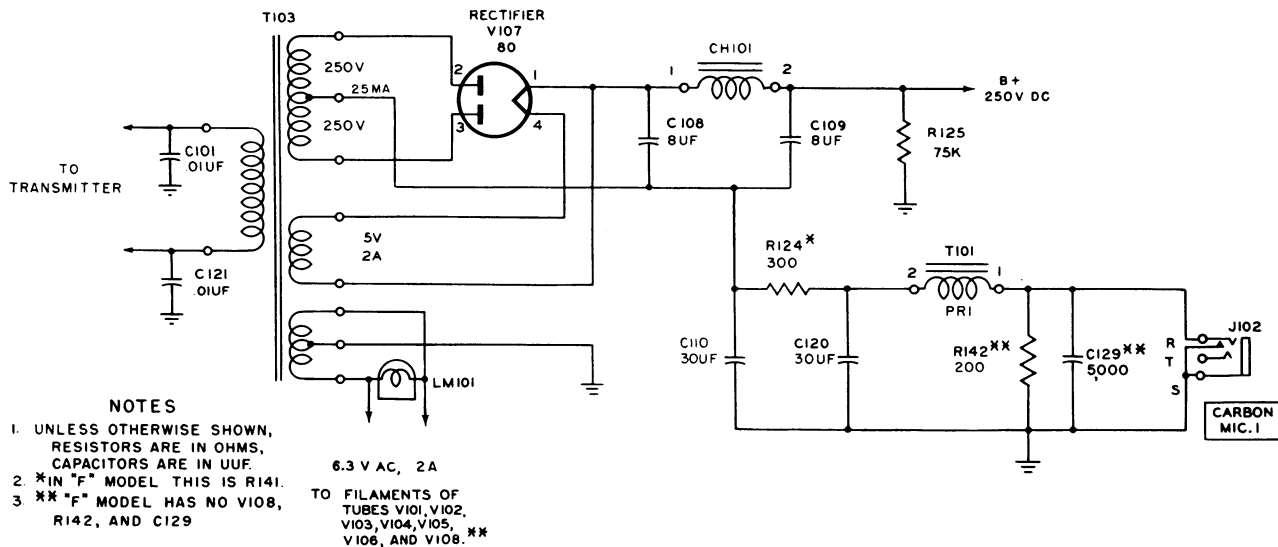

Figure 12. Sidetone oscillator and buffer, schematic diagram.



TM 5054-23

Figure 13. Speech Amplifiers BC-614-E and -F, power supply, schematic diagram.

by the values of C117, C118, and the grid resistors. The audio output of the sidetone oscillator appears across SIDETONE VOLUME control R137.

### 38. Sidetone Buffer

(fig. 12)

The purpose of the sidetone buffer is to isolate the headphones from the sidetone oscillator and to provide a low-impedance output to which the headphones are connected. Since tube V108 (6J5) is connected as a cathode-follower, the gain of the stage is less than 1.

a. Plate voltage is applied through decoupling resistor R126. Resistor R122 is the cathode-biasing resistor for tube V108 and also acts as the load resistor. Grid excitation voltage for tube V108 is obtained from the movable contact on R137 (SIDETONE VOLUME control) which also serves as the grid d-c return to ground. R137 controls the volume level of the sidetone signal applied to the grid of tube V108; resistor R138 limits the maximum signal that can be applied to approximately two-thirds of the available output of the sidetone oscillator.

b. The output voltage appearing across R122 is applied to the headphones through resistor R141. The output impedance of tube V108 is approximately 2,000 ohms; accordingly, resistor R141 is connected in series with the cathode of tube V108 to function as a current limiter.

c. Speech Amplifier BC-614-F does not include a sidetone buffer. To provide sufficient output, a

portion of the sidetone oscillator output is fed to the third and fourth a-f amplifiers. It then is taken from a voltage-dividing network at the secondary of the output transformer through a switch to connector SO-102 and to the appropriate receiver.

### 39. Power Supply

(figs. 13 and 14)

Plate and filament voltages for the tubes in the speech amplifier, and microphone current for a carbon microphone are supplied by the speech-amplifier power supply.

a. Transformer T103 furnishes all tubes with filament voltage and, in addition, it supplies the a-c plate voltage for rectifier tube V107. Tube V107 (80) is connected in a full-wave rectifier circuit. The rectified output voltage is applied to a pi-section filter consisting of filter choke coil CH101 and filter capacitors C108 and C109. Resistor R125 is the bleeder resistor for the speech-amplifier power supply. The primary leads to transformer T103 are bypassed for rf by capacitors C101 and C121. Lamp LM101 is connected across the 6.3-volt winding of the power transformer. It lights a red jeweled indicator on the front of the speech amplifier when the power is turned on by means of the FILAMENT POWER switch located on the front panel of the transmitter.

b. Resistors R145 and R146 form a voltage divider between the B+ lead and ground. The junction between these two resistors is approxi-

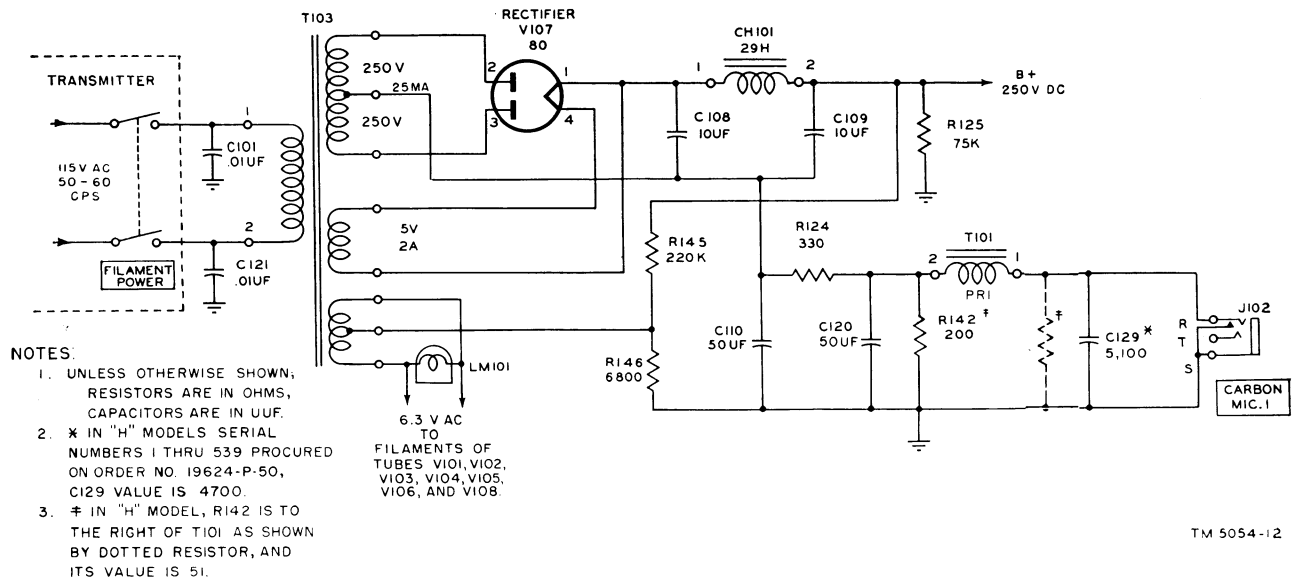

Figure 14. Speech Amplifiers BC-614-H and -I, power supply, schematic diagram.

mately 8 volts dc (positive) above the chassis ground. By connecting the center tap of the 6.3-volt secondary of transformer T103 to the junction of the resistors, the filaments of tubes V101 through V106 and V108 are held above ground. This reduces the tendency for a 60-cycle hum to be injected, by capacitive action, into the cathode circuits of the tubes (especially V101).

c. The current required to operate the carbon microphone is obtained from the negative return of the power supply load. When the microphone is not in the circuit, the ring and the grounded sleeve of J102 are shorted by the contacts of J102. This places the primary of transformer T101 in parallel with R142; this combination is in series with R124 which is connected to the center tap of the h-v secondary winding of T103. When the carbon microphone is inserted into CARBON MIC. 1 jack J102, the contacts mentioned above are opened and the microphone is placed in series with the primary of T101. The current flowing through the primary winding of T101 will flow through the microphone when the microphone switch is closed. Capacitor C129 is connected across the microphone and serves as an h-f bypass capacitor to reduce microphone hiss and r-f interference which may enter the amplifier by way of the microphone cord. R142 is effectively in parallel with the microphone, thus limiting the current through the microphone. Resistor R124 and capacitors C120 and C110 form a pi-section filter which filters all the a-c hum voltage from the current supplied to the microphone.

## 40. Sockets, Controls, and Meter

a. *CARBON MIC. 1 Jack and Control* (figs. 7 and 15). The CARBON MIC. 1 jack is used when a carbon microphone, such as Microphone T-17 or T-45, is available. The cord of each of these microphones is equipped with a Plug PL-68 which fits into jack J102. When the microphone plug is inserted into J102 and the switch is depressed, the microphone is placed in the B-current line. The other contacts of the switch on the microphone short the tip of J102 to ground; these contacts normally are used to complete a relay circuit in the external equipment. Capacitor C124 prevents sparking across the microphone switch contacts when breaking the dc through the relay, and C123 acts as an r-f bypass to prevent h-f interference from entering the amplifier by way of the microphone cord. The CARBON MIC. 1 control R123 functions as a gain control for the speech amplifier when a carbon microphone is used.

b. *DYNAMIC MIC. 2 Socket and Control* (figs. 7 and 16). The DYNAMIC MIC. 2 socket is used when a dynamic microphone, such as Microphone T-50, is available. The cord of this microphone is equipped with an amphenol connector which fits into connector SO-101. When the microphone is connected to SO-101 and the switch is depressed, the a-f signal from the microphone is applied to the amplifier through pins No. 1 and 3 on SO-101 (fig. 16). The microphone switch, when depressed, shorts terminal 2 on

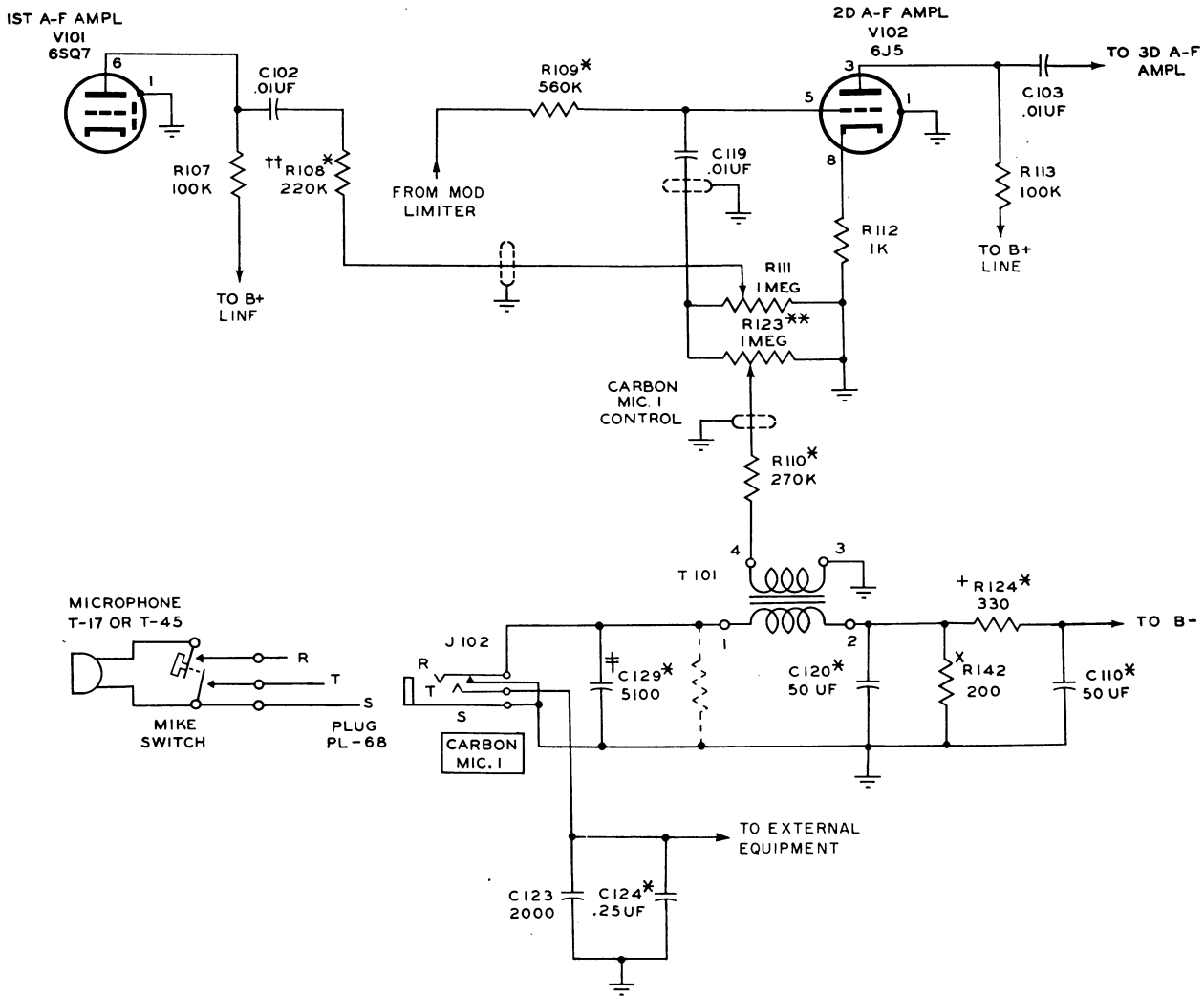

**NOTES:**

1. UNLESS OTHERWISE SHOWN, RESISTORS ARE IN OHMS, CAPACITORS ARE IN UUF.
2. \* COMPONENT VALUES: (VALUES SHOWN ABOVE ARE FOR MODEL I)

COMPONENT	R108	R109	R110	R124	C110	C120	C124	C129
VALUE IN "E"	200K SEE NOTE 7	500K	250K	300	30UF	30UF	.35 UF	5,000
VALUE IN "F"	200K	500K	250K	SEE NOTE 3	30UF	30UF	.35 UF	SEE NOTE 5

3. + THIS RESISTOR IS R141 IN MODEL "F".
4. X R142 IS NOT USED IN "F" MODEL, AND IT IS ON THE OTHER SIDE OF T101 (AT POSITION INDICATED BY DOTTED RESISTOR) IN MODELS "E" AND "H". ITS VALUE IN H MODEL IS 51.
5. \* THIS CAPACITOR DOES NOT EXIST IN THE "F" MODEL.
6. \*\* THIS RESISTOR IS R142 IN MODEL "F".
7. ++ RESISTOR R108 OMITTED ON SOME "E" MODELS.
8. IN "H" MODELS SERIAL NUMBERS 1 THRU 539 PROCURED ON ORDER NO. 19624-P-50, C124 IS .35UF, AND C129 IS 4700. ALL OTHER "H" MODELS ARE IDENTICAL WITH MODEL "I".

TM 5054-13

Figure 15. Carbon microphone circuit, schematic diagram.

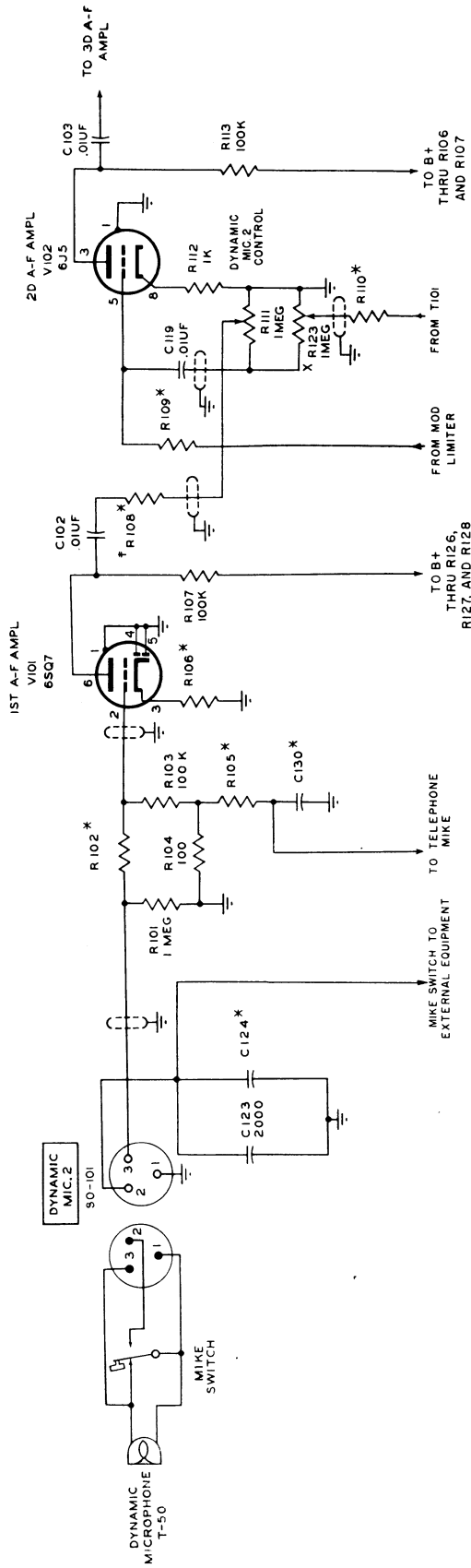

MODELS E, H, AND I

NOTES:

1. UNLESS OTHERWISE SPECIFIED, ALL CAPACITORS ARE IN UF.
  2. \* R108 OMITTED IN SOME E MODELS.
  3. X R123 IS R142 IN F MODEL (SAME VALUE)
  4. \* COMPONENT VALUES:
- VALUES LISTED UNDER H APPLY ONLY TO H MODELS SERIAL NUMBERS 1 THRU 539 PROCURED ON ORDER NO. 19624-P-50. ALL OTHER H MODELS ARE IDENTICAL WITH THE I MODEL.

COMPONENT	E	F	H	I
C124	.35 UF	.35 UF	.25 UF	.25 UF
C130	5,000	NOT USED	4,700	5,100
R102	3.3 MEG	1 MEG	3.3 MEG	3.3 MEG
R105	25K	5K	27K	27K
R106	5K	1K	4,700	4,700
R108	200K	200K	220K	220K
R109	500K	500K	560K	560K
R110	250K	250K	270K	270K

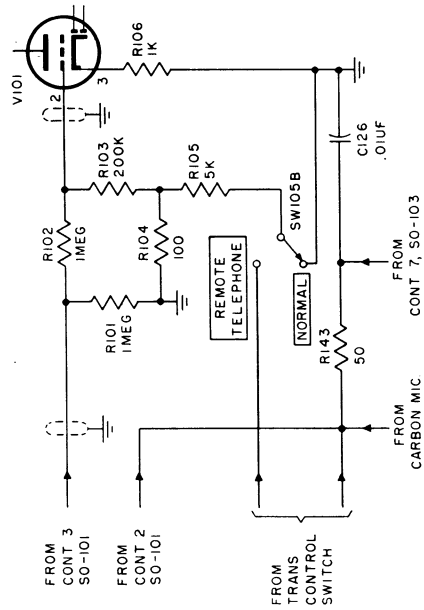

1ST A-F AMPL INPUT, F MODEL

B

Figure 16. Dynamic microphone circuit, schematic diagram.



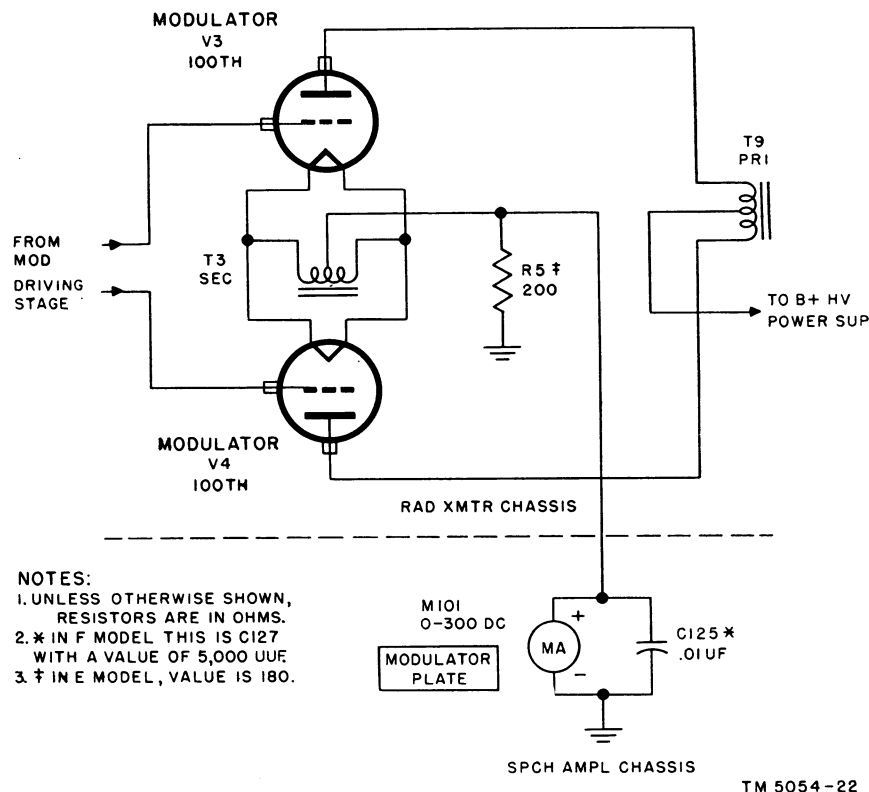

Figure 17. MODULATOR PLATE meter, functional schematic diagram.

SO-101 to ground. Terminal 2 normally is used to complete a relay circuit in the external equipment. C124 and C123 serve the same purpose as mentioned in *a* above. DYNAMIC MIC. 2 control R111 functions as the gain control for the speech amplifier when dynamic microphone or telephone is used to modulate the transmitter.

*c. Modulation Limiter Control* (figs. 7 and 11). LIMITER CONTROL R134 is located on the front panel of the speech amplifier behind a cover plate. Its purpose is to control the amplitude of the a-f signal applied to modulation limiter tube V105. It is preset to apply a part of the audio voltage present at the fourth a-f amplifier input to V105. The control is provided with a slotted shaft which is accessible when the cover plate is removed. See paragraph 51 for instructions as to the proper procedure for adjustment of the modulation limiter control.

*d. Sidetone Volume Control* (figs. 3 and 12). SIDETONE VOLUME control R137 is located on the rear side of the speech-amplifier chassis. Its purpose is to control the amplitude of the a-f signal applied to the grid of sidetone buffer tube

V108. This control does not appear in the F model of this equipment.

*e. Key Jack* (figs. 7 and 27). The KEY jack located on the front panel of the speech amplifier is connected in the transmitter. The jack accommodates Plug PL-55. The transmitter can be keyed for e-w operation by inserting a key plug into this jack.

**Caution:** When the transmitter is keyed from this jack, the receiver-disabling circuits do not operate. Be sure, therefore, that neither radio receiver is tuned to the transmitter frequency or a harmonic thereof.

*f. Modulator Plate Meter* (figs. 7 and 17). MODULATOR PLATE meter M101 indicates the d-c current to class B modulator tubes V3 and V4 in Radio Transmitter BC-610-(\*). Correct zero-signal bias to tubes V3 and V4 is obtained by adjusting the MODULATOR BIAS control (located on the front panel of the transmitter) while observing the indication of the meter. When modulating the transmitter, the microphone gain controls are adjusted properly by observing the indication of the meter on voice peaks.

*g. TO BC-610 Socket* (figs. 7 and 27). The TO BC-610 (SO-103 in models E, H, and I, and SO-104 in F model) socket is used to connect the speech amplifier to the transmitter. The terminals on this socket are utilized for the following purposes:

- (1) Terminals No. 1 and No. 3 connect the 115-volt a-c supply from the transmitter to the speech amplifier.
- (2) Terminal No. 2, models E, H, and I, connects the KEY jack (J101) in the speech amplifier and completes the circuit from the control or junction box through terminal No. 2 on connector SO-102, to the cathode circuit of the r-f oscillator in the transmitter; model F connects the KEY jack (J101) in the speech amplifier to the cathode circuit of the r-f oscillator in the transmitter, and places the cathode circuit of the sidetone oscillator (V106) in parallel with the cathode circuit of the r-f oscillator in the transmitter.
- (3) Terminal No. 4 completes the circuit from the control box or junction box through terminal No. 6 on SO-102 in the speech amplifier to the plate power and antenna shorting relays in the transmitter.
- (4) Terminal No. 5 inserts MODULATOR PLATE meter M101 of the speech amplifier in the center tap return lead of filament transformer T3 and in parallel with bias resistor R5 in the transmitter.
- (5) Terminals No. 6 and 7 connect the audio output of the speech amplifier to the a-f driver input in the transmitter.
- (6) Terminal No. 8 completes the ground circuit between the speech amplifier and the transmitter.

*h. TO JB-70 Socket* (figs. 7 and 27). The TO JB-70 (SO-102) socket is used to connect the speech amplifier to the control box or junction box. The terminals on this socket are utilized for the following purposes:

- (1) Terminal No. 1 completes the cathode circuit of the sidetone oscillator in the speech amplifier to ground through a switch in the control box or junction box.
- (2) Terminal No. 2 connects to terminal No. 2 on connector SO-103 in the speech amplifier. Provides a means for keying the transmitter from an auxiliary piece of equipment.
- (3) Terminal No. 3 connects the telephone microphone to the speech amplifier.
- (4) Terminal No. 4 connects the press-to-talk microphone switch to the relay circuit in the junction box or control box.
- (5) Terminal No. 5 connects the output of the sidetone buffer in the speech amplifier to the headsets through a switch in the control box or junction box.
- (6) Terminal No. 6 connects to terminal No. 4 on connector SO-103 in the speech amplifier to actuate the plate power and antenna shorting relays in the transmitter from an auxiliary piece of equipment.
- (7) Terminal No. 7 connects to terminal No. 3 on connector SO-103 in the speech amplifier to complete the 115-volt a-c common return for actuating the plate power and antenna shorting relays in the transmitter from an auxiliary piece of equipment.
- (8) Terminal No. 8 completes the ground circuit between the speech amplifier and the junction box or control box.

# CHAPTER 5

## FIELD MAINTENANCE INSTRUCTIONS

*Note.* This chapter contains information for field maintenance. The amount of repair that can be performed by units having field maintenance responsibility is limited only by the tools and test equipment available, and by the skill of the repairman.

### Section I. TROUBLE SHOOTING AT FIELD MAINTENANCE LEVEL

**Warning:** When servicing Speech Amplifier BC-614-(\*), be extremely careful of any exposed high voltages. Always disconnect the power cable before doing any testing. Keep one hand in pocket when measuring socket voltages with the probe. Before touching any part after the voltage is shut off, short the part to ground.

#### 41: Trouble-Shooting Procedures

*a. General.* The tests listed below will aid in isolating the source of trouble. Follow the procedure in the order given. Remember that servicing procedure should cause no further damage to the amplifier.

*b. Service Procedure.* The first step in servicing a defective amplifier is to sectionalize the fault. This means tracing the fault to the *stage or circuit* responsible for the abnormal operation. The second step is to localize the fault to the defective *part* in that circuit. Some faults such as burned-out resistors or shorted transformers often can be located by sight and smell. Most faults, however, must be localized by checking voltages and resistances. The service procedure is summarized as follows:

- (1) *Visual inspection.* Visual inspection frequently reveals the stage in which the trouble exists. This inspection is valuable in avoiding additional damage to the speech amplifier, which might occur through improper servicing methods, and in forestalling future failures. When failure is encountered and the cause is not immediately apparent, check as many of the items below as is practicable before starting a detailed examination of the speech amplifier. If possible, obtain information from the operator of the equipment regarding performance at the time trouble occurred. A visual check

of the following items ordinarily will determine the faulty part.

- (a) Wiring for loose or poorly soldered connections, frayed or burned insulation or stretched leads.
  - (b) Resistors for blistering or discoloration caused by overheating.
  - (c) Worn, broken, or disconnected cords or plugs.
  - (d) Wires broken because of excessive vibration.
  - (e) Defective tubes.
- (2) *Voltage and resistance measurements.* These measurements (par. 44) prevent further damage to the speech amplifier from possible short circuits. Since these measurements give an indication of the condition of the filter circuits, their function is more than preventive.
  - (3) *Trouble-shooting chart.* The symptoms listed in this chart (par. 45) will aid greatly in localizing trouble.
  - (4) *Signal tracing.* The principal advantage of the signal tracing method (par. 47) is that it usually enables the repairman to localize a trouble accurately and quickly to a given stage when the general location of the trouble is not immediately evident from the above tests.
  - (5) *Intermittents.* In all these tests, the possibility of intermittents should not be overlooked. If present, this type of trouble often may be made to appear by

tapping or jarring the set. It is possible that the trouble is not in the speech amplifier itself but in the installation. In this event, test the installation, if possible.

## 42. Trouble-Shooting Data

Take advantage of the material supplied in this manual. It will help in the rapid location of faults. Consult the following trouble-shooting data:

Fig. or par. No.	Description
Figure 27	Speech Amplifier BC-614-E, schematic diagram.
Figure 19	Speech Amplifier BC-614-E, tube-socket voltage and resistance diagram.
Figure 21	Speech Amplifiers BC-614-H and -I, tube-socket voltage and resistance diagram.
Figure 22	Speech Amplifiers BC-614-H and -I, resistor-capacitor boards, voltage and resistance diagram.
Figure 23	Speech Amplifier BC-614-(*), B+ voltage distribution.
Figure 3	Speech Amplifiers BC-614-H and -I, top interior view of chassis.
Figure 18	Speech Amplifiers BC-614-H and -I, bottom interior view of chassis.
Figure 24	Final testing diagram.
Paragraph 42	Voltage and resistance measurements.
Paragraph 43	Trouble-shooting chart.
Paragraph 44	D-c resistances of transformers and coils.
Paragraph 45	Signal tracing.

## 43. Test Equipment Required for Trouble Shooting

The test equipment required for trouble shooting Speech Amplifier BC-614-(\* ) are listed below. The technical manuals associated with the test equipment also are listed.

Test equipment	Technical manual
Audio Oscillator TS-382A/U, or equal	TM 11-2684A
Tube Testers I-177 and I-177-A, or equal.	TM 11-2627
Multimeter TS-352/U, or equal	TM 11-5527

## 44. Voltage and Resistance Measurements

a. Trouble within the speech amplifier often may be detected by checking the resistance of the B+ circuit *before* applying power to the equipment. This will prevent damage to the power supply.

b. Make the following measurement with the a-c power off: Place an ohmmeter between pin No. 1 or No. 4 of rectifier tube V107 and ground. The reading should be approximately 57,000 ohms ( $\pm 10$  percent).

c. Before making the power supply test, check the line voltage to the speech amplifier with a voltmeter to make sure that it is correct. Figures 19 through 21 show the voltage and resistance values at the tube sockets; figure 22 shows the voltage and resistance values at the resistor-capacitor boards; and figure 23 shows the B+ voltage distribution. All voltage and resistance measurements are to chassis ground.

## 45. Trouble-Shooting Chart

The following chart is supplied as an aid in locating trouble in the speech amplifier. This chart lists the symptoms which the repairman observes, either visually or audibly, while making a few simple tests, and also indicates how to localize trouble quickly to the particular stage or circuit of the unit. The signal tracing tests outlined in paragraph 47 then can be used to supplement this procedure and to determine the defective stage. Once the trouble has been localized, a tube check and voltage and resistance measurements of this stage or circuit ordinarily should be sufficient to isolate the defective part. Normal voltage and resistance measurements are given in figures 19 through 22.

Symptoms	Probable trouble	Correction
1. Filament voltage present at all tubes, but no plate voltage.	1. Rectifier tube V107 defective. The 250-volt secondary winding of transformer T103 burned out. Filter capacitor C108 or C109 shorted. Filter choke CH101 open.	1. Replace tube V107. Replace transformer T103. Replace defective capacitor. Replace choke.
2. Transmitter can be modulated by a carbon microphone, but not by a dynamic microphone.	2. Tube V101 defective. Resistor R101, R102, R103, R104, R106, R107, R108, R111, or R128 defective. Capacitor C102 or C113 defective.	2. Replace tube. Replace defective resistor. Replace defective capacitor.
3. Transmitter can be modulated by a dynamic microphone or telephone, but not by a carbon microphone.	3. Resistor R110 or R123 defective. Transformer T101 defective. Capacitor C120, C110, or C129 shorted. Capacitor C119 open.	3. Replace defective resistor. Replace transformer. Replace shorted capacitor. Replace open capacitor.
4. Transmitter can be modulated by carbon or dynamic microphone, but not by telephone.	4. Resistor R105 defective. Capacitor C130 shorted.	4. Replace resistor. Replace capacitor.
5. Filament voltage and plate power supplied. Transmitter can be modulated. Sidetone lacking during c-w operation.	5. Tube V106 or V108 defective. Resistor R135, R136, R137, R138, R139, R140, R122, or R141 defective. Defect in junction box or control box. Capacitor C117, C118, or C128 defective.	5. Replace defective tube. Replace defective resistor. Refer to system technical manual. Replace defective capacitor.
6. Filament voltage and plate power supplied to all tubes. Transmitter can be modulated. Speech limiter fails to limit speech peaks.	6. LIMITER CONTROL R134 defective. Tube V105 defective. Transformer T104 defective. Capacitor C114, C115, or C116 defective. Resistor R109, R129, R130, R131, R132, or R133 defective.	6. Replace resistor. Replace tube. Replace transformer. Replace defective capacitor. Replace defective resistor.

#### 46. D-C Resistances of Transformers and Coil

The d-c resistances of the transformer windings and of the coil in Speech Amplifier BC-614-(\*) are listed below:

Transformer or coil	Terminals	Ohms
T101	1 to 2	15
	3 to 4	18
T102	1 to 2	375
	2 to 3	375
	4 to 5	24
T103	1 to 2	12
	6 to 7	450
	7 to 8	450
T104	2 to 3	700
	5 to 6	1,450
	7 to 8	1,450
CH101	1 to 2	550

#### 47. Signal Tracing

a. Connect the output of the audio oscillator to terminals No. 1 and No. 3 of connector SO-101 and adjust the oscillator for a frequency of 400 cycles with minimum output.

b. Connect the VTVM (vacuum-tube voltmeter) test prod to pin No. 2 of tube V101 through a .05- $\mu$ f (microfarad) capacitor and connect the ground prod to ground of the chassis. (Do not hold or touch the tip of the prod when making tests; this may give an erroneous reading.)

c. Adjust the output attenuator of the test oscillator so that the VTVM shows slight deflection of the needle.

d. Connect the VTVM test prod to pin No. 6 (plate) of tube V101. The VTVM now should show increased needle deflection.

e. Tabulate the new reading of the VTVM.

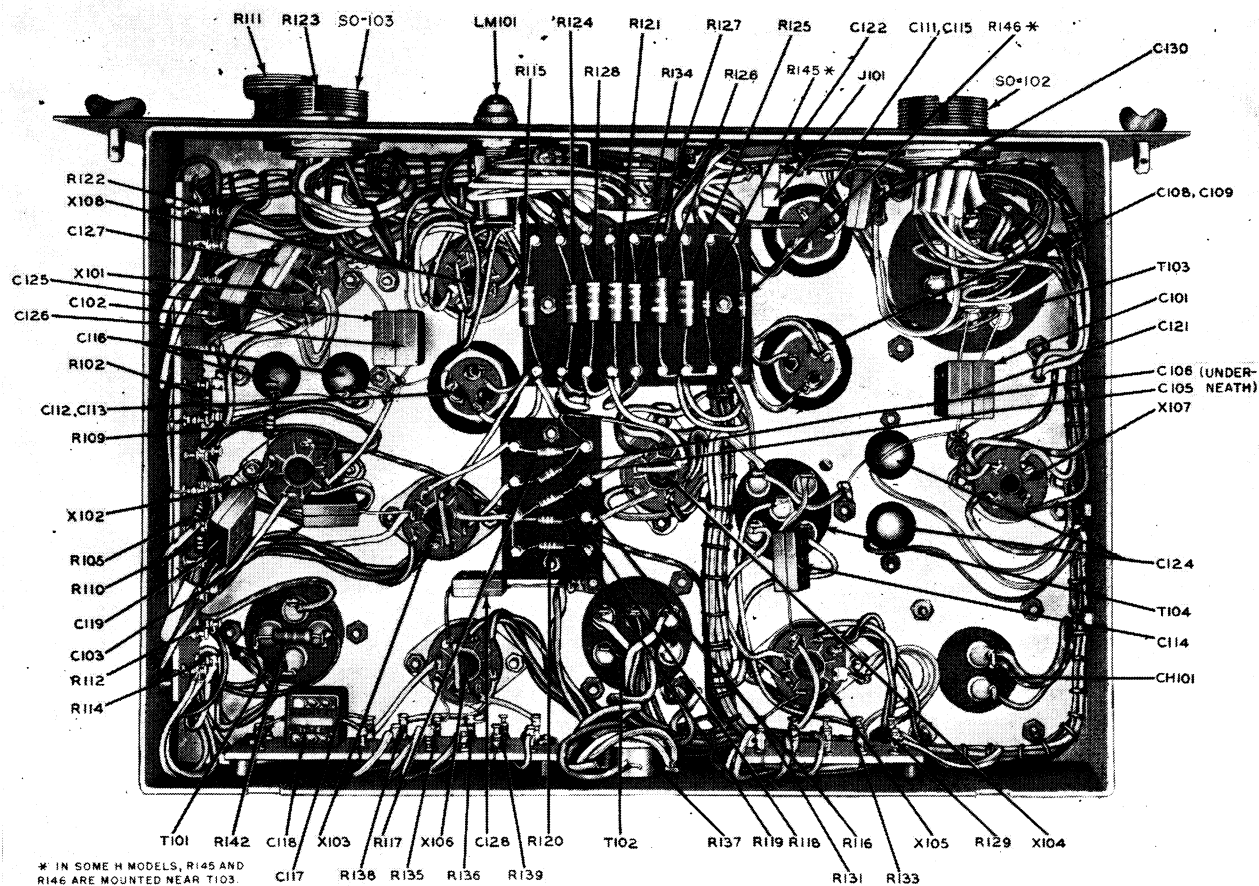

Figure 18. Speech Amplifiers BC-614-II and -I, bottom interior view of chassis.

f. Connect the VTVM test prod to pin No. 5 (grid) of tube V102. Adjust the DYNAMIC MIC. 2 volume control to maximum clockwise position. The VTVM needle now should deflect to the same reading as tabulated in *e* above. If the VTVM needle does not deflect, either capacitor C102 or C119 is probably open.

g. Connect the VTVM test prod to pin No. 3 (plate) of tube V102. The VTVM reading now should show definite increase. If the VTVM needle does not show any deflection, a defective tube V102 or defective circuit components in the second a-f stage are probably causing the loss of signal.

h. Place the VTVM test prod on pin No. 1 (grid) of tube V103. The VTVM needle should indicate the same position as in *g* above. If the VTVM needle fails to show any deflection, coupling capacitor C103 is probably open.

i. Place the VTVM test prod on pin No. 4 (grid) of tube V103. The VTVM needle now should be in the same position as in *g* above. If the VTVM needle fails to show any deflection, coupling capacitor C103 or C106 is open, or tube V103 is defective. Return the needle to the same VTVM reading as in *e* above. If the VTVM cannot be returned to the same position by adjusting the level or attenuator control of the audio oscillator, turn the multiplier switch to the next highest multiplier at which it can be made to assume the same position.

j. Place the VTVM test prod on pin No. 2 (plate) of tube V103. The VTVM reading now should show a definite increase. If the VTVM needle does not show any deflection, this indicates a defective tube V103 or defective components in the V103 stage.

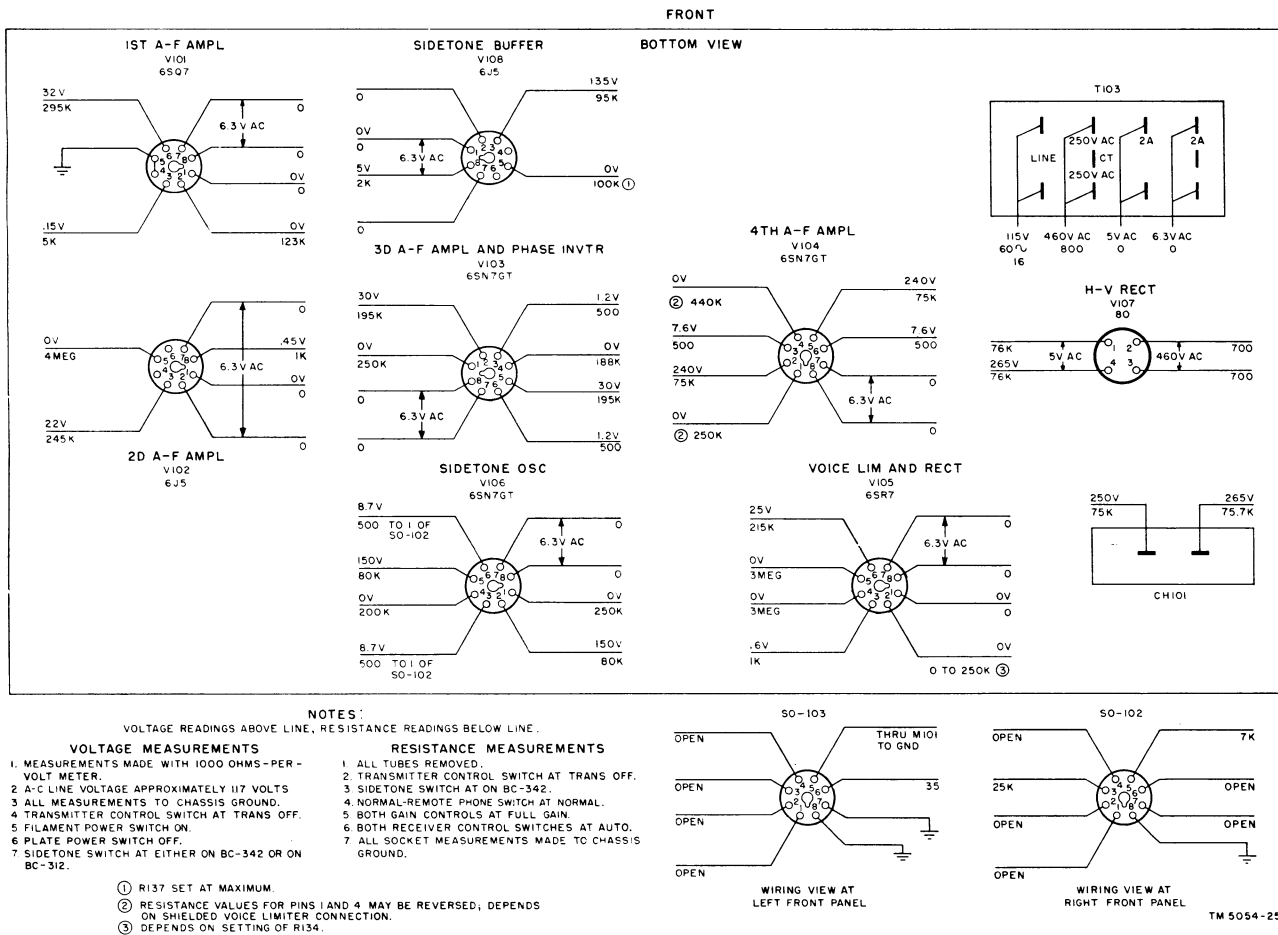

Figure 19. Speech Amplifier BC-614-E, tube-socket voltage and resistance diagram.

k. Place the VTVM test prod on pin No. 5 (plate) of tube V103. The VTVM needle should indicate the same as in *j* above.

l. Place the VTVM test prod on pin No. 4 (grid) of tube V104. The VTVM needle should indicate the same as in *j* above. If the VTVM needle fails to show any deflection, coupling capacitor C106 is probably open.

m. Place the VTVM test prod on pin No. 1 (grid) of tube V104. The VTVM needle should indicate the same as in *j* above. If the VTVM needle fails to show any deflection, coupling capacitor C105 is probably open. Return the needle to the same VTVM reading as in *g* above by adjusting the audio oscillator level or attenuator control.

n. Place the VTVM test prod on pin No. 5 (plate) of tube V104. The VTVM reading now should show an increase. If it does not, a defective tube V104 or defective components in the V104 stage are indicated.

o. Place the VTVM test prod on pin No. 2 (plate) of tube V104. The VTVM needle should indicate the same position as in *n* above.

Note. When making the above tests, an indication of increased strength is to be expected as the signal is traced from input to output. At any point in the speech amplifier where the signal is lost or is decreased in strength, a defective stage is indicated. The exact defect in the particular stage then can be located by a voltage and resistance analysis of the stage (figs. 19 through 22).

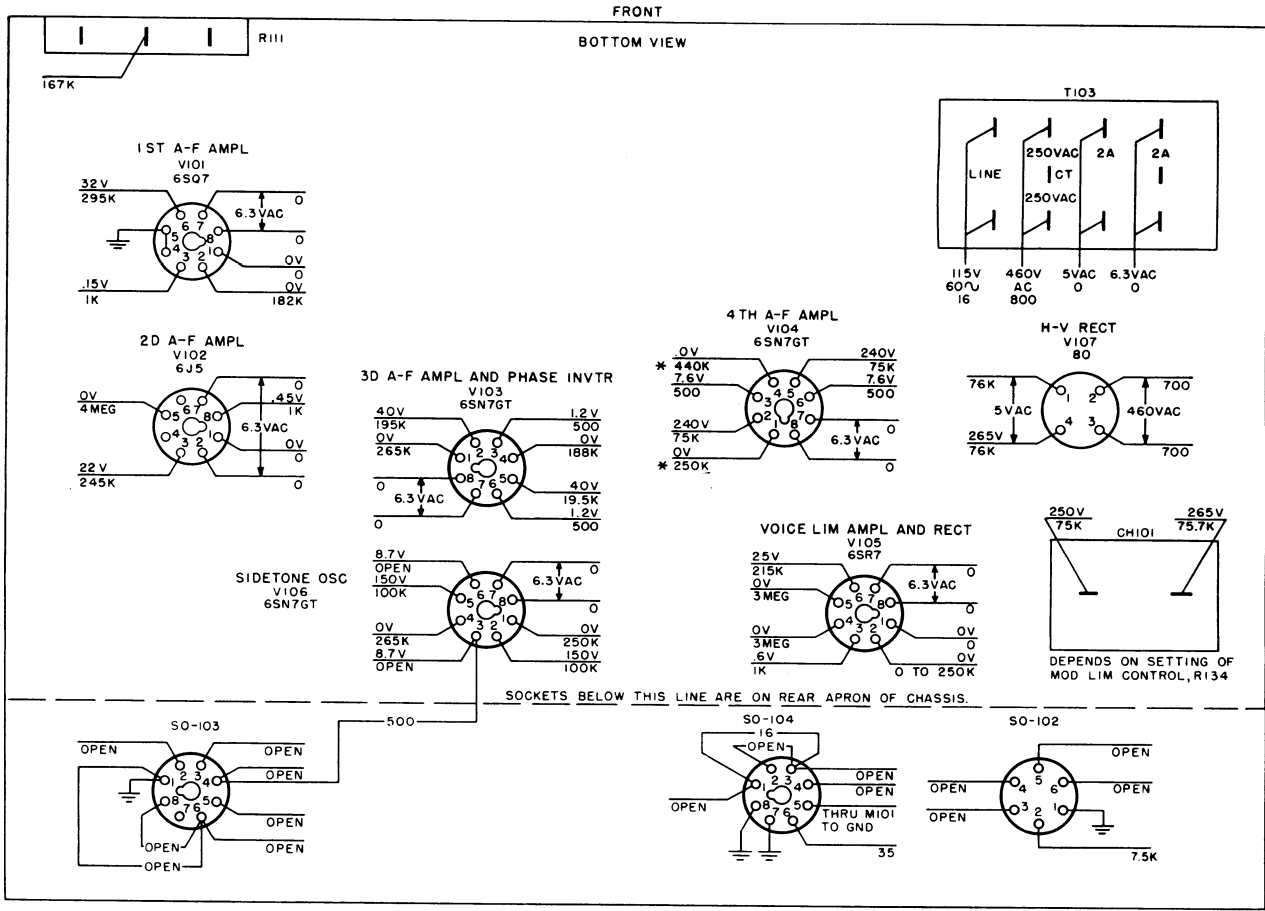

- NOTES:
- |   |  |
|---|--|
| <p style="text-align: center;">VOLTAGE READINGS ABOVE LINE, RESISTANCE READINGS BELOW LINE.</p> <p style="text-align: center;">VOLTAGE MEASUREMENTS</p> <ol style="list-style-type: none"> <li>1. MEASUREMENTS MADE WITH 1000 OHMS-PER-VOLT METER.</li> <li>2. A-C LINE VOLTAGE APPROXIMATELY 117 VOLTS.</li> <li>3. ALL MEASUREMENTS MADE TO CHASSIS GROUND.</li> <li>4. TRANSMITTER CONTROL SWITCH AT TRANS OFF.</li> <li>5. FILAMENT POWER SWITCH ON.</li> <li>6. PLATE POWER SWITCH OFF.</li> <li>7. SIDETONE SWITCH AT EITHER ON BC-342 OR ON BC-312.</li> </ol> | <p style="text-align: center;">RESISTANCE MEASUREMENTS</p> <ol style="list-style-type: none"> <li>1. ALL TUBES REMOVED.</li> <li>2. TRANSMITTER CONTROL SWITCH AT TRANS OFF.</li> <li>3. SIDETONE SWITCH AT ON BC-342.</li> <li>4. NORMAL-REMOTE PHONE SWITCH AT NORMAL.</li> <li>5. BOTH GAIN CONTROLS AT FULL GAIN.</li> <li>6. BOTH RECEIVER CONTROL SWITCHES AT AUTO.</li> <li>7. ALL SOCKET MEASUREMENTS MADE TO CHASSIS GROUND.</li> </ol> |
|---|--|
- \* RESISTANCE VALUES FOR PINS 1 AND 4 OF V104 MAY BE REVERSED, DEPENDS ON SHIELDED VOICE LIMITER CONNECTION.

TM 5054 - 24

Figure 20. Speech Amplifier BC-614-F, tube-socket voltage and resistance diagram.



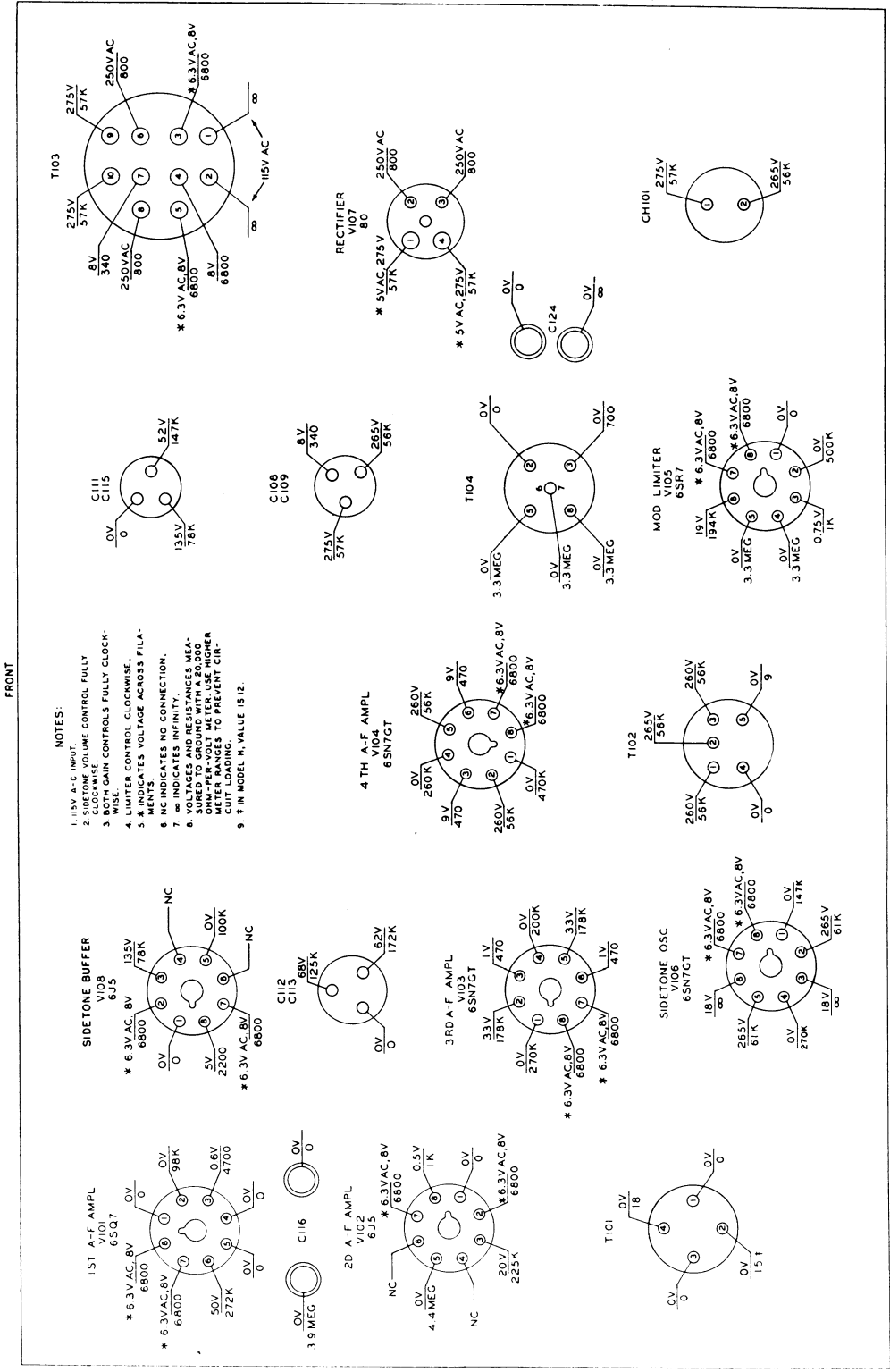
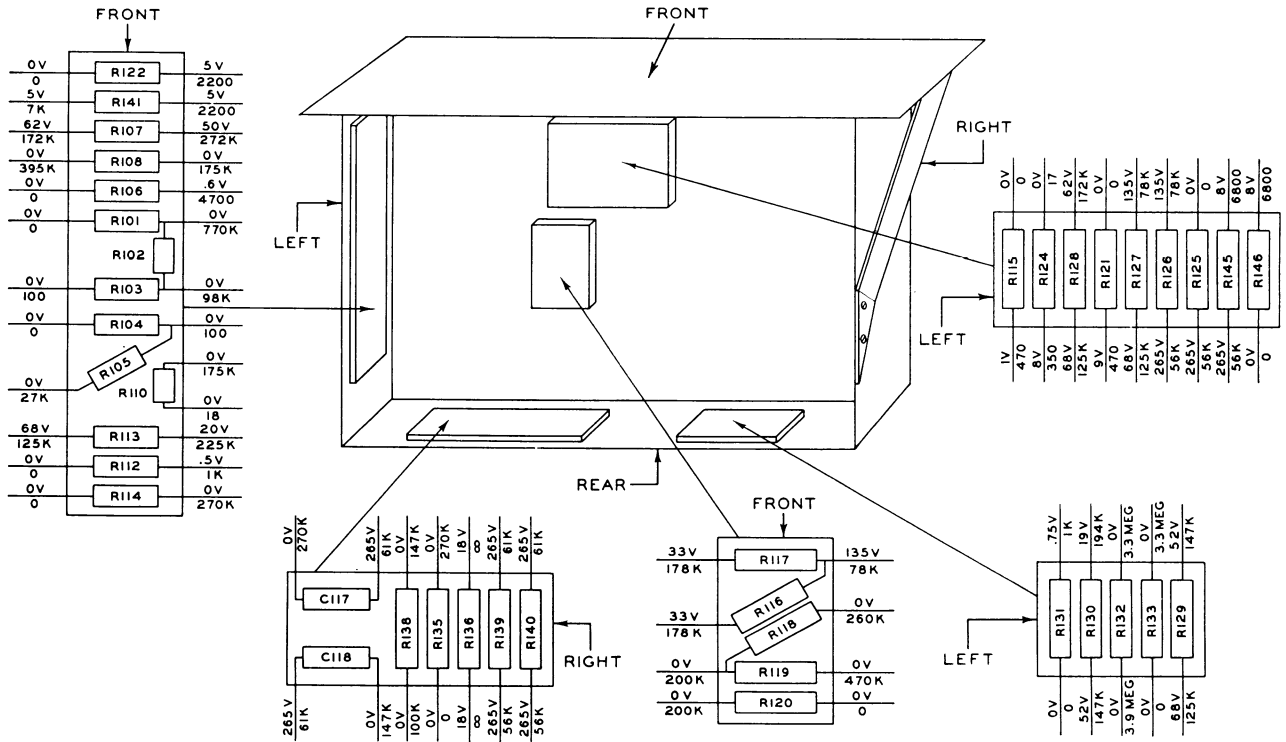

Figure 21. Speech Amplifiers BC-614-H and -I, tube-socket voltage and resistance diagram.



NOTES:

1. 115V A-C INPUT.
2. CARBON MIC. 1 CONTROL FULLY CLOCKWISE. RESISTANCE READING (175K) OF R110 WILL BE LESS WITH OTHER SETTINGS OF CONTROL.
3. DYNAMIC MIC. 2 CONTROL FULLY CLOCKWISE. RESISTANCE READINGS OF R108 WILL VARY DIRECTLY WITH OTHER SETTINGS OF MIKE CONTROLS.
4. VOLTAGES AND RESISTANCES MEASURED TO GROUND (CHASSIS) WITH A 20,000 OHMS-PER-VOLT METER. USE HIGHER METER RANGES TO REDUCE CIRCUIT LOADING.

TM 5054-18

Figure 22. Speech Amplifiers BC-614-H and -I, resistor-capacitor boards, voltage and resistance diagram.

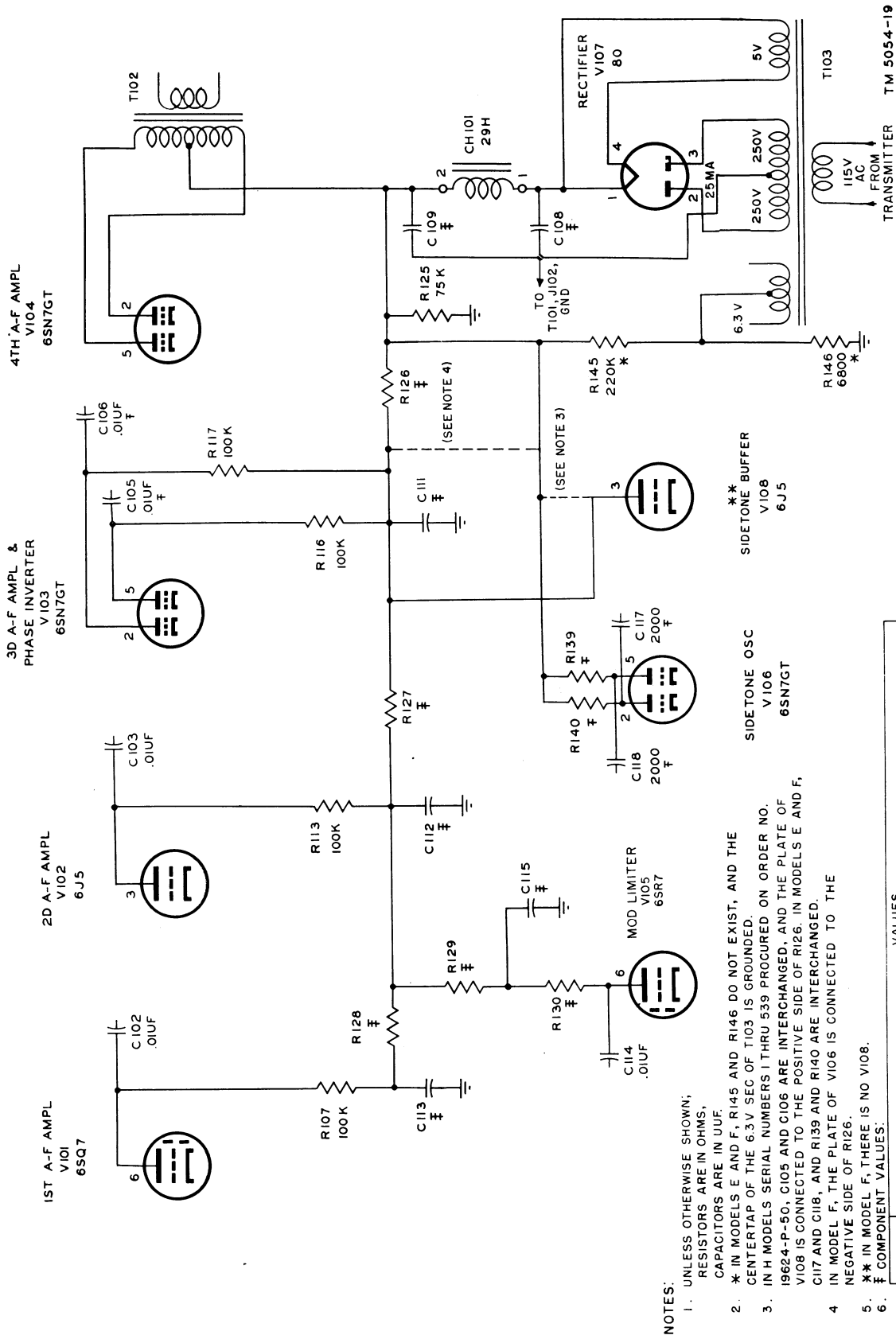

- NOTES:
- UNLESS OTHERWISE SHOWN, RESISTORS ARE IN OHMS, CAPACITORS ARE IN UUF.
  - \* IN MODELS E AND F, R145 AND R146 DO NOT EXIST, AND THE CENTERTAP OF THE 6.3V SEC OF T103 IS GROUNDED.
  - IN H MODELS SERIAL NUMBERS 1 THRU 539 PROCURED ON ORDER NO. 19624-P-50, C105 AND C106 ARE INTERCHANGED, AND THE PLATE OF V108 IS CONNECTED TO THE POSITIVE SIDE OF R126. IN MODELS E AND F, C117 AND C118, AND R139 AND R140 ARE INTERCHANGED.
  - IN MODEL F, THE PLATE OF V106 IS CONNECTED TO THE NEGATIVE SIDE OF R126.
  - \*\* IN MODEL F, THERE IS NO V108.
  - † COMPONENT VALUES:

\*\* SIDETONE BUFFER  
V108  
6J5

SIDETONE OSC  
V106  
6SN7GT

MODEL	VALUES	R126 AND R129	R127, R128 AND R130	R139 AND R140
E AND F	8U	20K	50K	5K
H AND I	10U	22K	47K	4700

Figure 23. Speech Amplifier BC-614 (\*), B+ voltage distribution.

## Section II. REPAIRS

### 48. Replacement of Parts

The parts of Speech Amplifier BC-614-(\*) are easily accessible when the chassis is removed from the cabinet. To remove the chassis, release the four winged panel locks and pull the chassis straight out of the cabinet.

*a. General.* Careless replacement of parts often makes new faults inevitable. Note the following points:

- (1) Before a part is unsoldered, note the position of the leads. If the part, such as a transformer, has a number of connections, tag each of the leads to it; this insures proper reconnection.
- (2) Be careful not to damage other leads by pulling or pushing them out of the way.
- (3) Do not allow drops of solder to fall into the unit because they may cause short circuits.
- (4) A carelessly soldered connection may create a new fault. It is very important to make well-soldered joints, since a poorly soldered joint is one of the most difficult faults to find.
- (5) When a part is replaced, it must be placed in the same position as the original one. A part which has the same electrical value but different physical size may cause trouble in high-gain circuits. Give particular attention to proper grounding when replacing a part. Use the same ground as in the original wiring. Failure to observe the precautions may result in decreased gain or in possible oscillation of the circuit.

*b. New Connections.* To avoid misconnections which would cause additional damage to the equipment, be sure to double-check new connections that involve power supply wiring.

*c. Record of Connections.* It may be necessary to take out other circuit elements and parts to remove or to replace a defective part. Make a careful record of the connections to each part removed.

*d. Limiter Control R134.* To remove the LIMITER CONTROL, first loosen the resistor mounting strip just behind the control by unscrewing the two nuts which hold the strip to its mounting. Move the strip to the rear. Unsolder the three leads to the control and tag each lead. Unscrew the two nuts which hold the control to the front of the chassis, and remove the control. Replace the control in reverse order.

*e. Microphone Gain Controls.* To remove either microphone gain control, first disconnect the leads to the control and tag each one. Remove the knob by loosening the setscrew which holds it on the shaft. Remove the nut and washer which secure the control to the panel, and take the control off the panel. Replace the control in reverse order.

### 49. Refinishing

Instructions for refinishing are given in paragraph 30. If the equipment is worn and the panel is marred badly, the exterior should be refinished in accordance with instructions in TM 9-2851 before it is returned to use.

## Section III. ALINEMENT PROCEDURES

### 50. Test Equipment Required for Alinement and Adjustment

The following items should be available to accomplish the alinement and adjustment of the speech amplifier.

- Audio Oscillator TS-382A/U, or equal
- Radio Transmitter BC-610-(\*)

### 51. Modulation Limiter

The modulation limiter in Speech Amplifier BC-614-(\*) has been set properly to provide a minimum of 3-db compression at 100 percent

modulation, and no change in setting is recommended. Readjustment should be made *only* if the LIMITER CONTROL has been reset. No adjustment in the field is recommended unless an audio oscillator is available. To adjust the LIMITER CONTROL, perform the following steps:

*a.* Disconnect the dynamic microphone from connector SO-101 on the panel of the speech amplifier.

*b.* Connect a 400-cycle audio generator to terminals No. 1 and No. 3 of connector SO-101. The grounded side of the generator output should

be connected to terminal No. 1. See figure 16 for connector SO-101 connections.

*c.* Turn on the transmitter and adjust it for phone operation.

*d.* Remove the metal plate under the panel marking LIMITER CONTROL on the speech amplifier. The screw driver adjusted control located behind this plate is the LIMITER CONTROL.

*e.* Turn the LIMITER CONTROL to the extreme counterclockwise position.

*f.* Turn on the 400-cycle generator and adjust its output and the DYNAMIC MIC. 2 gain control for a MODULATOR PLATE meter reading of 225 ma.

*g.* Turn the LIMITER CONTROL clockwise until the MODULATOR PLATE meter reads 160 ma.

*h.* The modulation limiter now is adjusted for normal operation. Replace the metal plate and

secure it to the front panel. Reconnect the dynamic microphone and resume operation.

## 52. Sidetone Buffer

The SIDETONE VOLUME control, R137, serves as a volume control for the sidetone buffer. This control is mounted at the rear of the speech amplifier chassis. It is not necessary to remove the chassis from the cabinet to make the sidetone adjustment, since a hole is provided at the rear of the cabinet. When Speech Amplifier BC-614-(\*) is used with a system, the following procedure is used in making the SIDETONE VOLUME adjustment.

*a.* Set the switch in the control box or junction box to the position required for the receiver being used.

*b.* Plug the headset into the receiver.

*c.* Close the key which is plugged into the junction box or control box and, while listening in the headset, adjust the SIDETONE VOLUME control to the desired level.

## Section IV. FINAL TESTING

### 53. General

This section is intended as a guide in determining the gain and quality of Speech Amplifier BC-614-(\*) after it has been repaired. The tests outlined in paragraphs 56 through 62 may be performed by maintenance personnel with adequate test equipment and the necessary skills. Properly repaired equipment passing these test requirements will give uniformly satisfactory service.

### 54. Test Equipment Required for Final Testing

The instruments needed for testing the repaired equipment are listed below:

Audio Oscillator TS-382A/U, or equal.

Two output VTVM, low-range meters, such as Electronic Multimeter ME-6/U or equal.

Oscilloscope OS-8A/U, or equal.

Multimeter TS-352/U, or equal.

Spectrum Analyzer TS-723/U, or equal.

Two 100-ohm resistors,  $\frac{1}{2}$ -watt each.

500-ohm resistor, 10-watt.

2,000-ohm resistor,  $\frac{1}{2}$ -watt.

250,000-ohm resistor,  $\frac{1}{2}$ -watt.

### 55. General Test Methods and Conditions

The speech amplifier under test is connected to the test equipment as shown in figure 24 and is tested under the following conditions unless noted otherwise.

*a.* An input line voltage of 117-volts ac, 50 to 60 cycles.

*b.* Normal room temperature and humidity.

*c.* A 500-ohm, 10-watt load resistor connected across terminals No. 4 and No. 5 of output transformer T102 (pins No. 6 and No. 7 of connector SO-103).

*d.* A 250,000-ohm,  $\frac{1}{2}$ -watt load resistor across terminals No. 1 and No. 3 of DYNAMIC MIC. 2 connector SO-101.

*e.* A 100-ohm,  $\frac{1}{2}$ -watt load resistor across carbon microphone terminals R and S of CARBON MIC. 1 jack J102.

*f.* A sine wave input signal of 400-cps.

*g.* Compression control (LIMITER CONTROL) set at fully counterclockwise (minimum) position.

*h.* Zero level dbm (decibels referred to 1 milliwatt).

## 56. Audio Gain

a. *CARBON MIC. 1 Input (J102)* (A of fig. 24).

- (1) Set the CARBON MIC. 1 gain control to the fully clockwise (maximum) position.
- (2) Set the DYNAMIC MIC. 2 gain control to the fully counterclockwise (minimum) position.
- (3) Connect the audio oscillator to jack J102.
- (4) Connect the audio output meter across the 500-ohm load between terminals No. 4 and No. 5 of output transformer T102.
- (5) Adjust the audio oscillator frequency to 400 cps and the gain control to the output required for a 4.95-volt (+17 dbm) reading on the audio output meter.
- (6) Connect the VTVM across the audio oscillator output. The reading should be .68 volt or less.

b. *DYNAMIC MIC. 2 Input (SO-101)* (B of fig. 24).

- (1) Set the DYNAMIC MIC. 2 gain control to the fully clockwise (maximum) position.
- (2) Set the CARBON MIC. 1 gain control to the fully counterclockwise (minimum) position.
- (3) Connect the audio oscillator to connector SO-101 (ground lead to terminal No. 1 and output lead to terminal No. 3).
- (4) Connect the audio output meter across the 500-ohm load between terminals No. 4 and No. 5 of output transformer T102.
- (5) Adjust the audio oscillator frequency to 400 cps and the gain control to the output required for a 4.95-volt (+17 dbm) reading on the audio output meter.
- (6) Connect the VTVM across the audio oscillator output. The reading should be .087 volt or less.

c. *Telephone Input (SO-102)* (C of fig. 24).

- (1) Set the DYNAMIC MIC. 2 gain control to the fully clockwise (maximum) position.
- (2) Set the CARBON MIC. 1 gain control to the fully counterclockwise (minimum) position.
- (3) Connect the audio oscillator to connector SO-102 (output lead to pin No. 3 and

ground lead to pin No. 8). For the F model, connect the oscillator to connector SO-103 (output lead to pin No. 5 and ground lead to pin No. 1). Set the transmitter control switch in the TRANS ON position and SW105 in the remote phone position. Connect a 100-ohm,  $\frac{1}{2}$ -watt resistor across these pins.

- (4) Connect the audio output meter across the 500-ohm load between terminals No. 4 and No. 5 of output transformer T102.
- (5) Adjust the audio oscillator frequency to 400 cps and the gain control to the output required for a 4.95-volt (+17 dbm) reading on the audio output meter.
- (6) Connect the VTVM across the audio oscillator output. The reading should be .68 volt or less.

## 57. Distortion

a. *CARBON MIC. 1 Input (J102)* (A of fig. 24).

- (1) Set the CARBON MIC. 1 gain control to the fully clockwise (maximum) position.
- (2) Set the DYNAMIC MIC. 2 gain control to the fully counterclockwise (minimum) position.
- (3) Connect the audio oscillator to jack J102.
- (4) Connect the distortion analyzer to the amplifier output.
- (5) Adjust the audio oscillator frequency to 400 cps and the gain control to the output required for a 4.95-volt (+17 dbm) reading at the output of the speech amplifier.
- (6) Read the distortion on the distortion meter. The reading should be 2.5 percent or lower.

b. *DYNAMIC MIC. 2 Input (SO-101)* (B of fig. 24).

- (1) Set the DYNAMIC MIC. 2 gain control to the fully clockwise (maximum) position.
- (2) Set the CARBON MIC. 1 gain control to the fully counterclockwise (minimum) position.
- (3) Connect the audio oscillator to connector SO-101 (ground lead to terminal No. 1 and output lead to terminal No. 3).
- (4) Connect the distortion analyzer to the amplifier output.

- (5) Adjust the audio oscillator frequency to 400 cps and the gain control to the output required for a 4.95-volt (+17 dbm) reading at the output of the speech amplifier.
- (6) Read the distortion on the distortion meter. The reading should be 2.5 percent or lower.

## 58. Frequency Response

### *a. CARBON MIC. 1 Input (A of fig. 24).*

- (1) Set the CARBON MIC. 1 gain control to the fully clockwise (maximum) position.
- (2) Set the DYNAMIC MIC. 2 gain control to the fully counterclockwise (minimum) position.
- (3) Connect the audio oscillator to jack J102.
- (4) Connect the audio output meter across the 500-ohm load between terminals No. 4 and No. 5 of output transformer T102.
- (5) Adjust the audio oscillator frequency to 400 cps and the gain control to the output required for a 4.95-volt (+17 dbm) reading on the audio output meter.
- (6) Change the audio oscillator frequency to 150 cps.
- (7) Read the output on the audio output meter. The reading should be less than 5 db down from the reading at 400 cps.
- (8) Change the audio oscillator frequency to 4,000 cps.
- (9) Read the output on the audio output meter. The reading should be less than 3 db down from the reading at 400 cps.

### *b. DYNAMIC MIC. 2 Input (B of fig. 24).*

- (1) Set the DYNAMIC MIC. 2 gain control to the fully clockwise (maximum) position.
- (2) Set the CARBON MIC. 1 gain control to the fully counterclockwise (minimum) position.
- (3) Connect the audio oscillator to connector SO-101 (ground lead to terminal No. 1 and output lead to terminal No. 3).
- (4) Connect the audio output meter across the 500-ohm load between terminals No. 4 and No. 5 of output transformer T102.
- (5) Adjust the audio oscillator frequency to 400 cps and the gain control to the output required for a 4.95-volt (+17 dbm) reading on audio output meter.

- (6) Change the audio oscillator frequency to 100 cps.
- (7) Read the output on the audio output meter. The reading should be less than 7 db down from the reading at 400 cps.
- (8) Change the audio oscillator frequency to 4,000 cps.
- (9) Read the output on the audio output meter. The reading should be less than 4 db down from the reading at 400 cps.

## 59. Hum Level

- a.* Set both microphone gain controls at maximum.
- b.* Connect the audio output meter across the 500-ohm load on the output transformer, terminals No. 4 and No. 5.
- c.* Read the hum level on the output meter. The reading should be less than 1 volt.

## 60. Compression (Limiter)

(B of fig. 24)

- a.* Set the DYNAMIC MIC. 2 gain control to the fully clockwise (maximum) position.
- b.* Set the CARBON MIC. 1 gain control to the fully counterclockwise (minimum) position.
- c.* Connect the audio oscillator to connector SO-101.
- d.* Connect the audio output meter across the 500-ohm load between terminals No. 4 and No. 5 of the output transformer.
- e.* Adjust the audio oscillator frequency to 400 cps and the gain control to the output required for a 4.95-volt (+17 dbm) reading on the audio output meter.
- f.* Set the LIMITER CONTROL to the fully clockwise (maximum) position.
- g.* Read the output on the audio output meter. The reading should be 1.65 volts (+7.5 dbm), or less.
- h.* Adjust the LIMITER CONTROL to give a reading of 2.5 volts (+11 dbm, 6 db down from +17 dbm).

## 61. Sidetone Oscillator and Amplifier

(D of fig. 24)

### *a. Models E, H, and I.*

- (1) Connect pin No. 1 to pin No. 8 of connector SO-102 to ground the sidetone oscillator cathode.

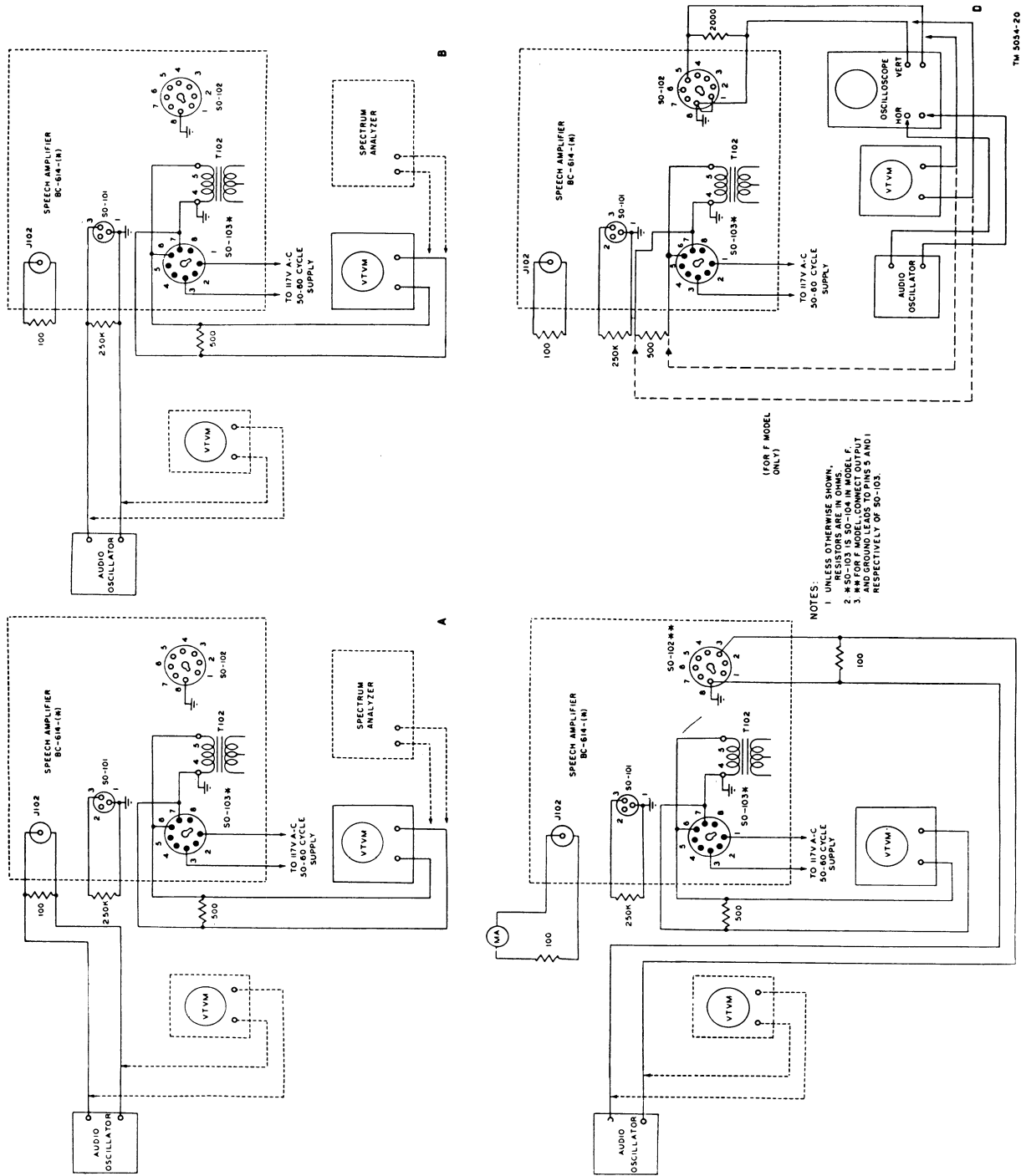

TM 5054-20

Figure 24. Final testing diagram.



- (2) Connect a 2,000-ohm,  $\frac{1}{2}$ -watt resistor from pin No. 5 to pin No. 8 (ground) of connector SO-102.
- (3) Connect the vertical input of the oscilloscope across the 2,000-ohm resistor.
- (4) Set the SIDETONE VOLUME control, R137, to the fully clockwise (maximum) position.
- (5) Observe the sidetone waveform and frequency on the oscilloscope. The waveform should appear as a differentiated square wave. The frequency should be between 850 cps and 1,250 cps. (This can be checked by comparison with the audio oscillator.)
- (6) Connect the audio output meter across the 2,000-ohm resistor in place of the oscilloscope. The voltage reading should be .7 volt or more.

- (7) Adjust the SIDETONE VOLUME control to give a reading of .5 volt on the audio output meter.

*b. Model F.*

- (1) Set the SIDETONE switch to either ON BC-312 or ON BC-342.
- (2) The output of the sidetone oscillator should be 3.46 volts (+6 dbm) measured across the 500-ohm resistance placed between terminals No. 4 and No. 5 of transformer T102.

## **62. Carbon Microphone Current**

(C of fig. 24)

Connect a milliammeter in series with the 100-ohm resistor across CARBON MIC. 1 jack J102. The reading should be less than 9.5 ma.

# CHAPTER 6

## SHIPMENT AND LIMITED STORAGE AND DEMOLITION TO PREVENT ENEMY USE

---

### Section I. SHIPMENT AND LIMITED STORAGE

#### 63. Disassembly

Refer to the disassembly paragraph in the technical manual for the system with which the speech amplifier will be used. Be sure that all cables and microphones are disconnected before attempting the removal of the amplifier from its installation.

#### 64. Repacking for Shipment or Limited Storage

*a.* The exact procedure used in repacking for shipment or limited storage depends on the mate-

rial available and the conditions under which the equipment is to be shipped or stored. Refer to paragraph 12 and reverse the unpacking instructions.

*b.* Whenever practicable, place a dehydrating agent such as silica gel inside the chests. Protect the cartons with a waterproof paper barrier. Seal the seams of the paper barrier with waterproof sealing compound or tape. Pack the protected chests in a padded wooden case, providing at least 3 inches of excelsior padding or some similar material between the paper barrier and the packing case.

### Section II. DEMOLITION OF MATÉRIEL TO PREVENT ENEMY USE

#### 65. General

The demolition procedures outlined in paragraph 66 will be used to prevent the enemy from using or salvaging this equipment. Demolition of the equipment will be accomplished only upon order of the commander.

#### 66. Methods of Destruction

*a. Smash.* Smash the controls, tubes, meter, capacitors, and transformers, using sledges, axes, handaxes, pickaxes, hammers, crowbars, or heavy tools.

*b. Cut.* Cut cords, headsets, and wiring, using axes, handaxes, or machetes.

*c. Burn.* Burn cords, resistors, capacitors, meter wiring, and technical manuals, using gasoline, kerosene, oil, flame throwers, or incendiary grenades.

*d. Bend.* Bend panel, cabinet, and chassis.

*e. Explosives.* If explosives are necessary, use firearms, grenades, or TNT.

*f. Disposal.* Bury or scatter the destroyed parts in slit trenches, fox holes, or other holes, or throw them into streams.

*g. Destroy Everything.*

## RESISTOR COLOR AND LETTER CODE

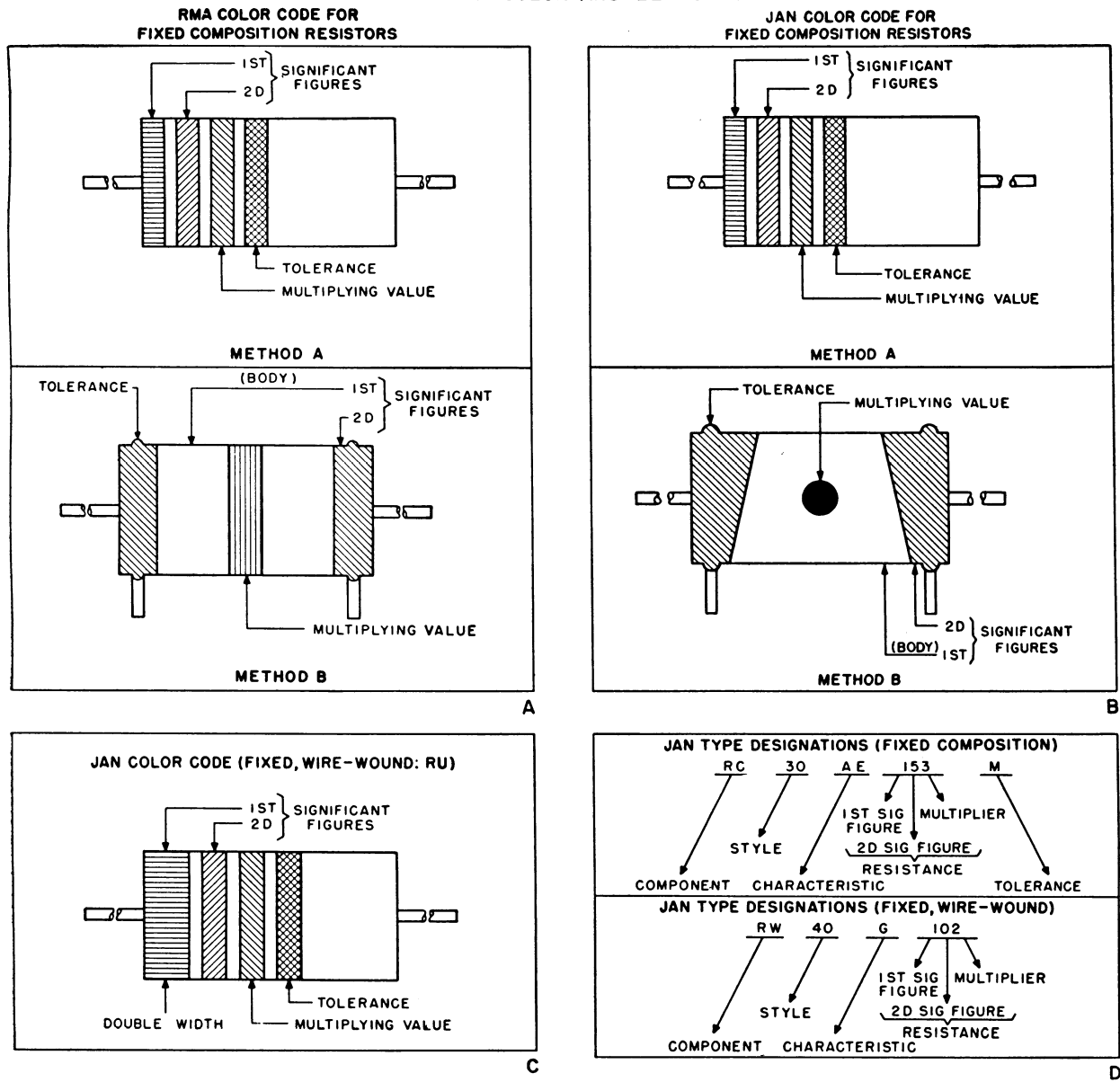

STANDARDS				
COLOR	SIGNIFICANT FIGURE	MULTIPLYING VALUE	TOLERANCE (%)	JAN LETTER TOLERANCE
BLACK	0	1	—	—
BROWN	1	10	± 1	F
RED	2	100	± 2	G
ORANGE	3	1,000	± 3	—
YELLOW	4	10,000	± 4	—
GREEN	5	100,000	± 5	—
BLUE	6	1,000,000	± 6	—
VIOLET	7	10,000,000	± 7	—
GRAY	8	100,000,000	± 8	—
WHITE	9	1,000,000,000	± 9	—
GOLD	—	0.1	± 5	J
SILVER	—	0.01	± 10	K
NO COLOR	—	—	± 20	M

- NOTES:**
1. RESISTORS WITH AXIAL LEADS ARE INSULATED. RESISTORS WITH RADIAL LEADS ARE NON-INSULATED.
  2. RMA: RADIO MANUFACTURERS ASSOCIATION.
  3. JAN: JOINT ARMY - NAVY.
  4. THESE COLOR AND NUMBER CODES GIVE ALL RESISTANCE VALUES IN OHMS.
  5. RESISTIVE COMPONENTS USED FOR LETTER TOLERANCES ARE: RC, RN, AND RU.
  6. WATTAGE FOR RW TYPES IS FOUND IN THE JAN SPECIFICATIONS UNDER CHARACTERISTICS.

TM RC.

Figure 25. Resistor color code.

## CAPACITOR COLOR AND LETTER CODES

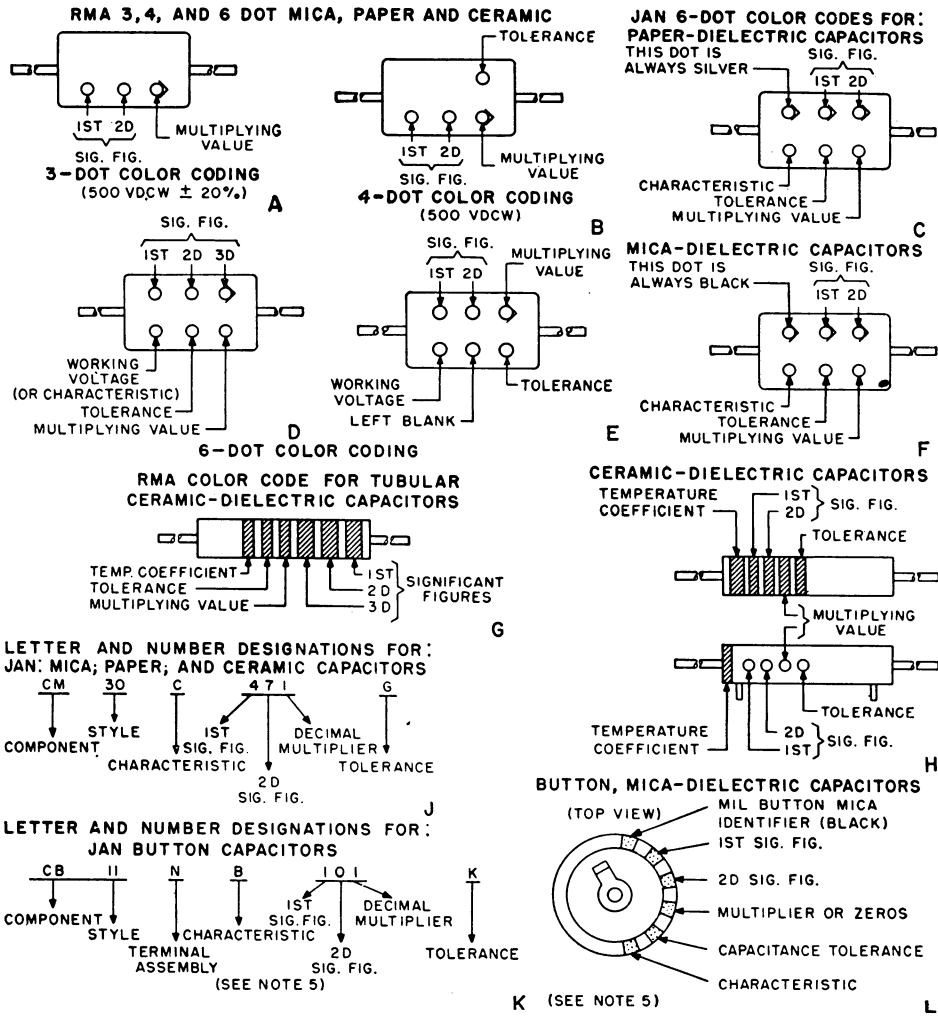

- STANDARDS -					JAN MICA-CM		JAN PAPER-CM		JAN CERAMIC-CC					
COLOR	SIG. FIG.	DECIMAL MULTIPLIER	% TOL.	VDCW	LETTER TOL.	CHARAC-TERISTIC	LETTER TOL.	CHARAC-TERISTIC	DEC. MULT.	%	LETTER DESIGN-NATION	UUF	LETTER DESIGN-NATION	CHARAC-TERISTIC
BLACK	0	1	±20	500	M	A	N	A	1	±20	M	±2.0	G	C
BROWN	1	10	±1	100	-	B	-	E	10	±1	F	-	-	H
RED	2	100	±2	200	G	C	-	H	100	±2	G	-	-	L
ORANGE	3	1,000	±3	300	-	D	N*	J	1,000	-	-	-	-	P
YELLOW	4	10,000	±4	400	-	E	-	P	-	-	-	-	-	R
GREEN	5	100,000	±5	500	-	F	-	R	-	±5	J	±0.5	D	S
BLUE	6	1,000,000	±6	600	-	G	-	S	-	-	-	-	-	T
VIOLET	7	10,000,000	±7	700	-	-	-	T	-	-	-	-	-	U
GRAY	8	100,000,000	±8	800	-	-	-	-	0.01	-	-	±0.25	C	B
WHITE	9	1,000,000,000	±9	900	-	-	-	-	0.1	±10	K	±1.0	F	SL
GOLD	-	0.1	±5	1,000	J	-	-	-	-	-	-	-	-	A
SILVER	-	0.01	±10	2,000	K	-	-	-	-	-	-	-	-	-
NO COLOR	-	-	±20	500	-	-	-	-	-	-	-	-	-	-

- NOTES
- JAN: JOINT ARMY-NAVY  
RMA: RADIO MANUFACTURERS ASSOCIATION
- THESE COLOR AND LETTER CODES GIVE CAPACITANCES IN MICROMICROFARADS
  - THIS TABLE IS ADAPTED FOR JAN AND RMA COLOR AND JAN LETTER TYPE DESIGNATIONS
  - CERAMIC AND MICA CAPACITORS, BOTH JAN AND RMA, ARE GENERALLY 500 VDCW
  - BUTTON CAPACITORS ARE GENERALLY 300 VDCW
  - READ BUTTON CAPACITOR TOLERANCE UNDER CERAMICS OF MORE THAN 10 UUF
  - CHARACTERISTICS ARE AVAILABLE IN JAN CAPACITOR SPECIFICATION MANUALS
  - THE COMPONENTS USED ABOVE FOR JAN LETTER TYPE DESIGNATIONS ARE:  
CM MICA BUTTON; CC CERAMIC; CM MICA MOULDED; CN PAPER MOULDED

TM CC

Figure 26. Capacitor color code.

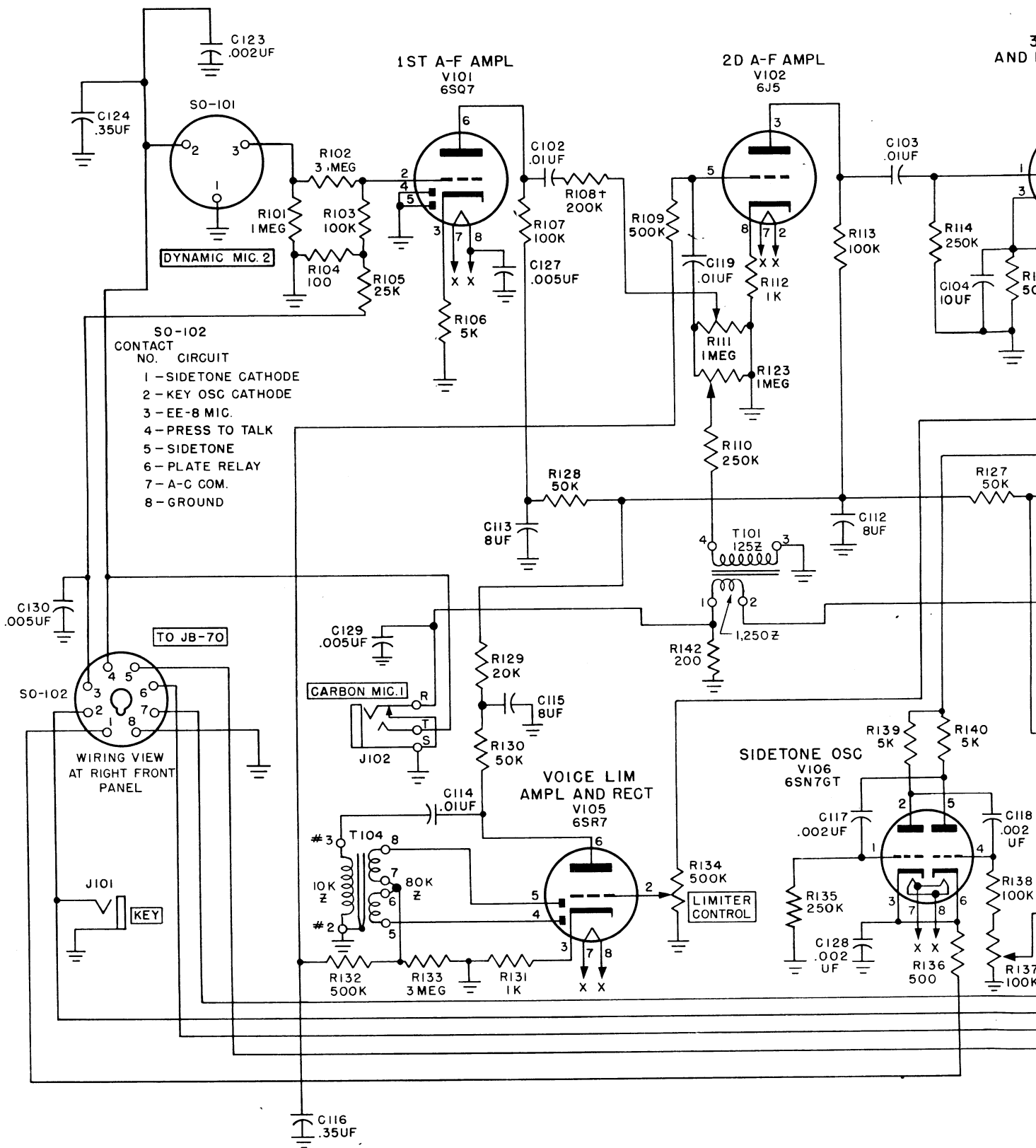
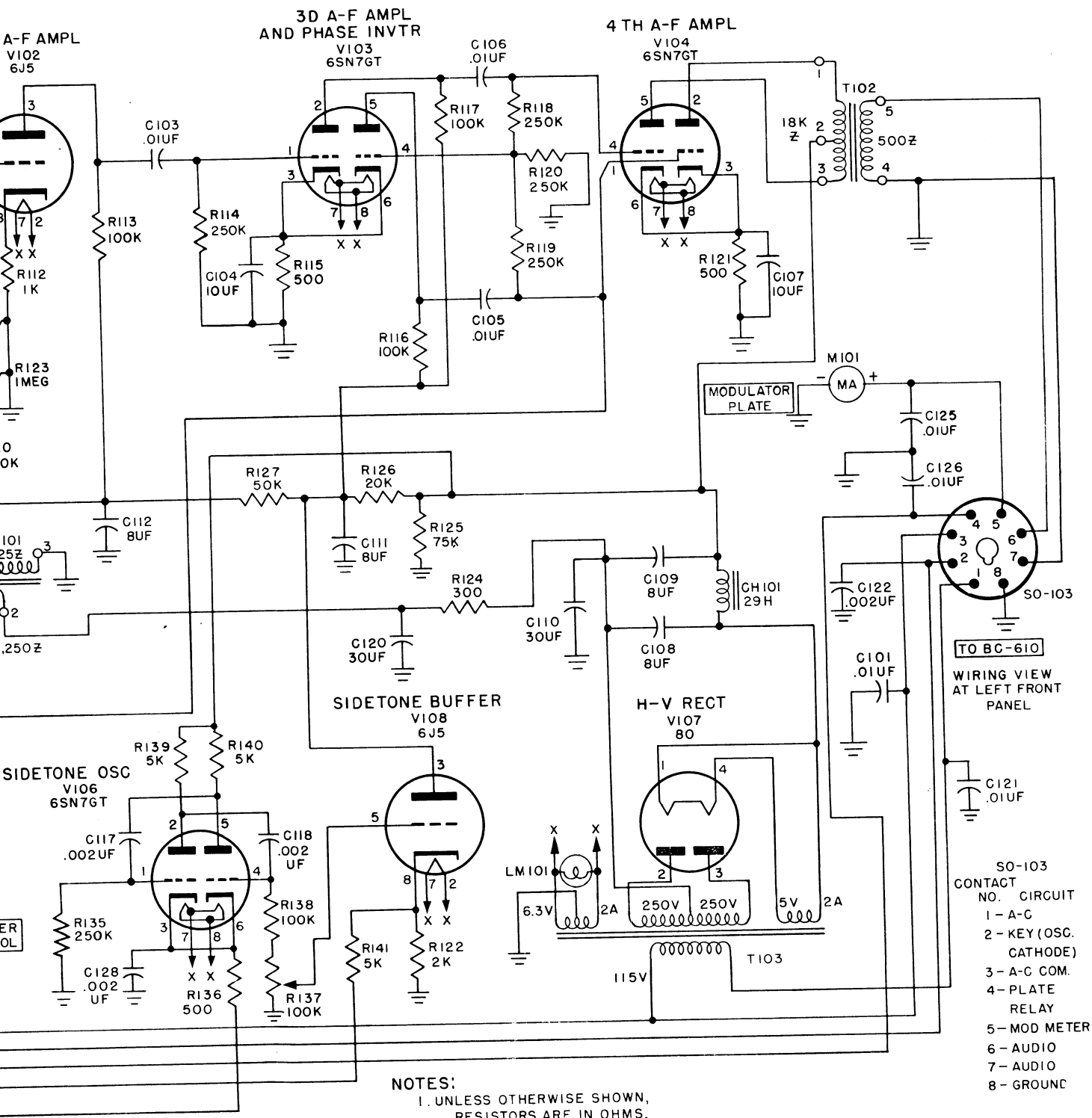

Figure 27. Speech Amplifier BC-614 E, schematic



**NOTES:**  
 1. UNLESS OTHERWISE SHOWN, RESISTORS ARE IN OHMS, CAPACITORS ARE IN UUF.  
 \* TERMINALS 2 AND 3 OF TRANSFORMER T104 ARE REVERSED IN SOME EQUIPMENT  
 † RESISTOR R108 OMITTED ON SOME EQUIPMENT.

- SO-103 CONTACT NO. CIRCUIT
- 1 - A-C
  - 2 - KEY (OSC. CATHODE)
  - 3 - A-C COM.
  - 4 - PLATE RELAY
  - 5 - MOD METER
  - 6 - AUDIO
  - 7 - AUDIO
  - 8 - GROUND

TM 5054-27

27. Speech Amplifier BC-614 E, schematic diagram.

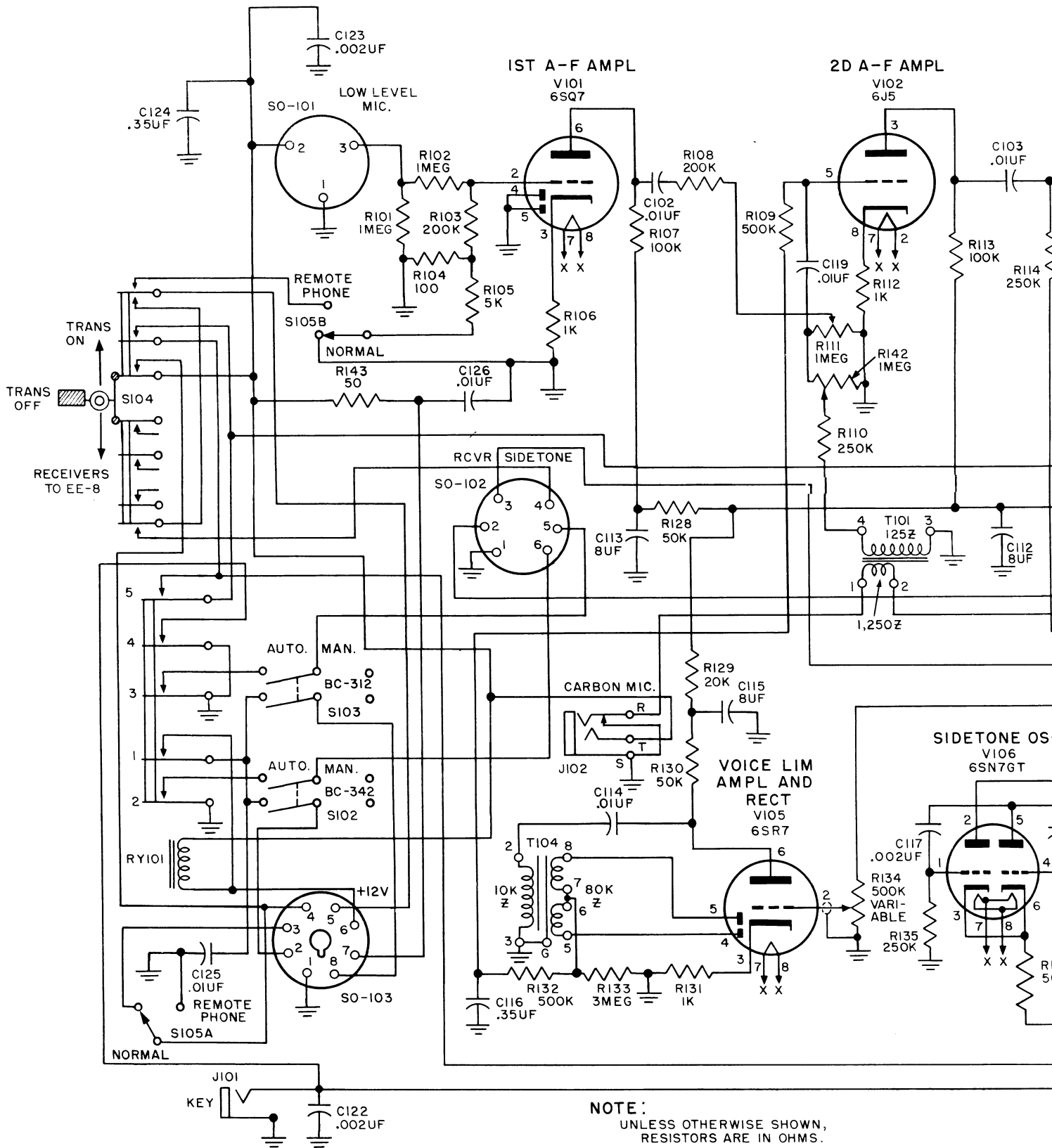

**NOTE:**  
UNLESS OTHERWISE SHOWN,  
RESISTORS ARE IN OHMS.

Figure 28. Speech Amplifier BC-614-F, so

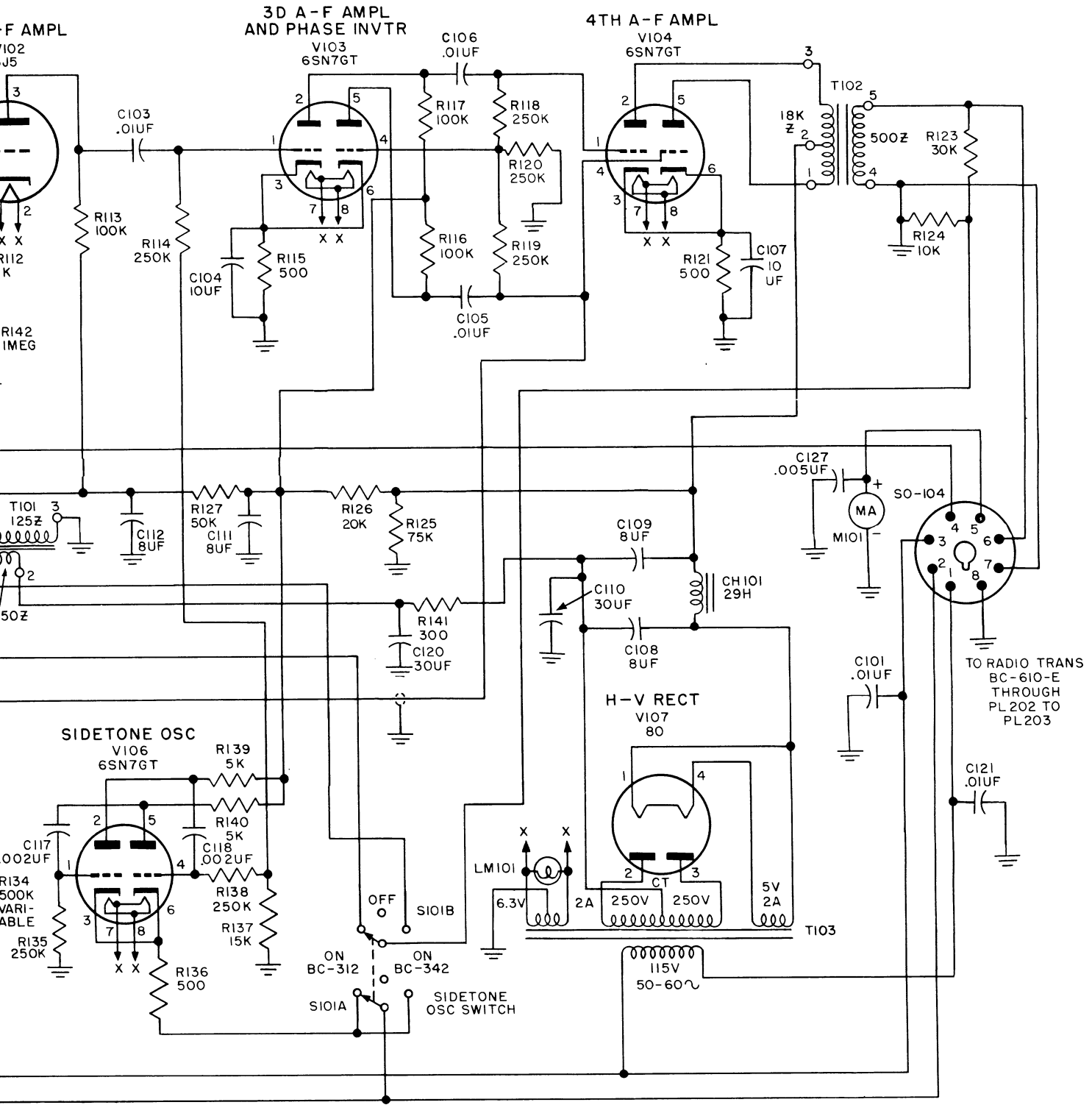

Amplifier BC-614-F, schematic diagram.

TM 5054-28

222350 O-52 (FACE P. 44) NO. 2



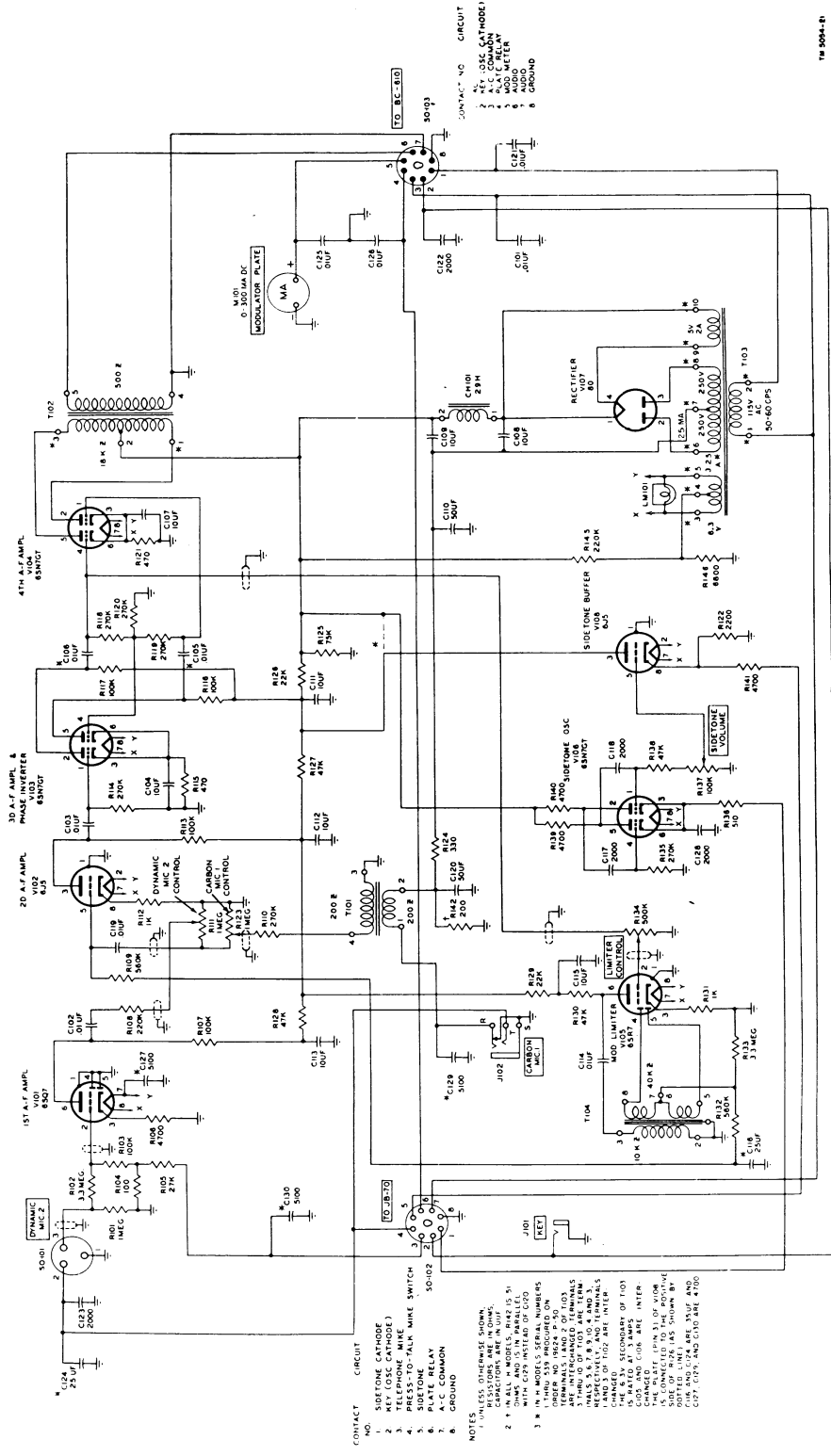

75 5044-P

Figure 29. Speech Amplifier BC-614-H and I, schematic diagram.



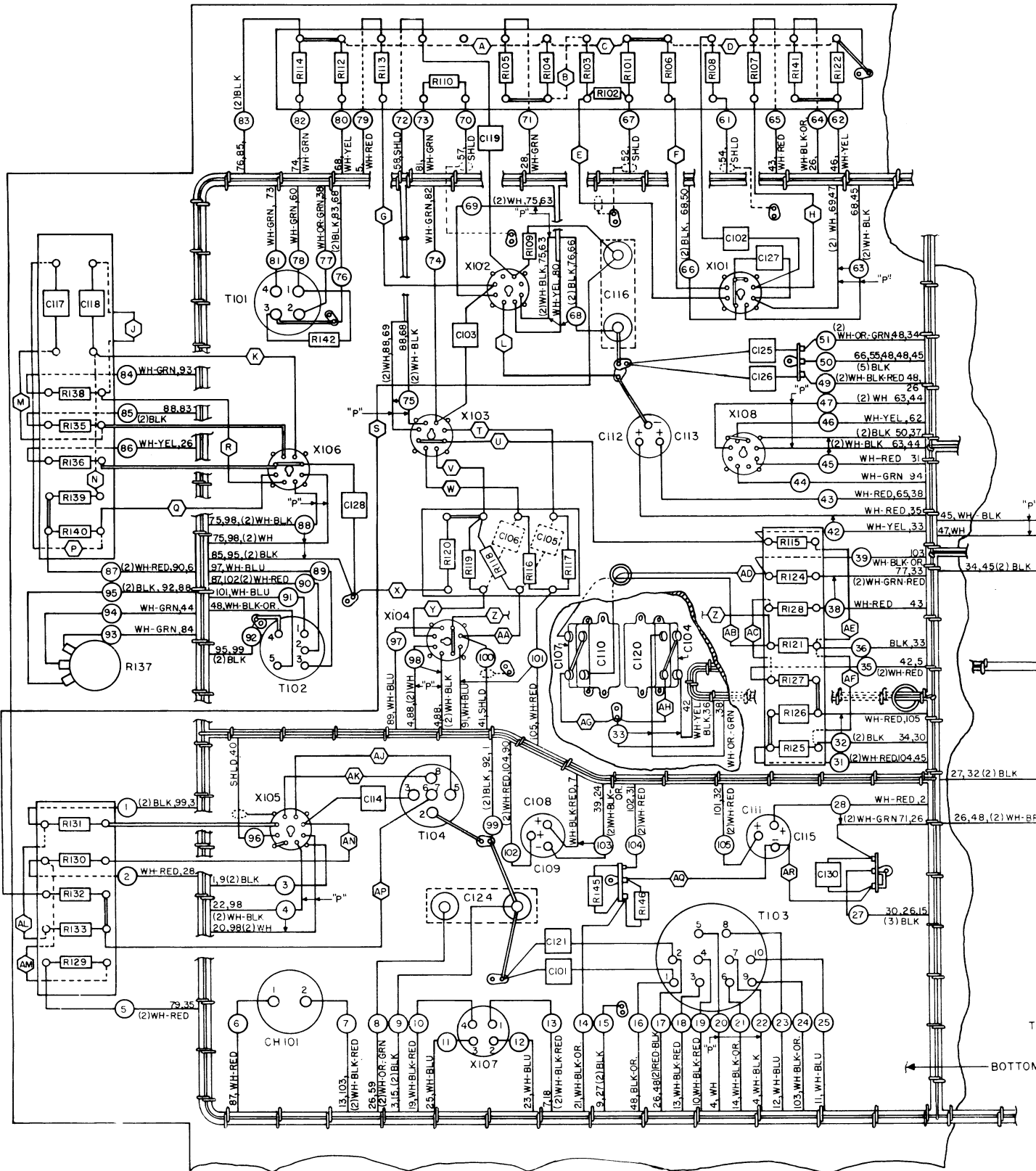
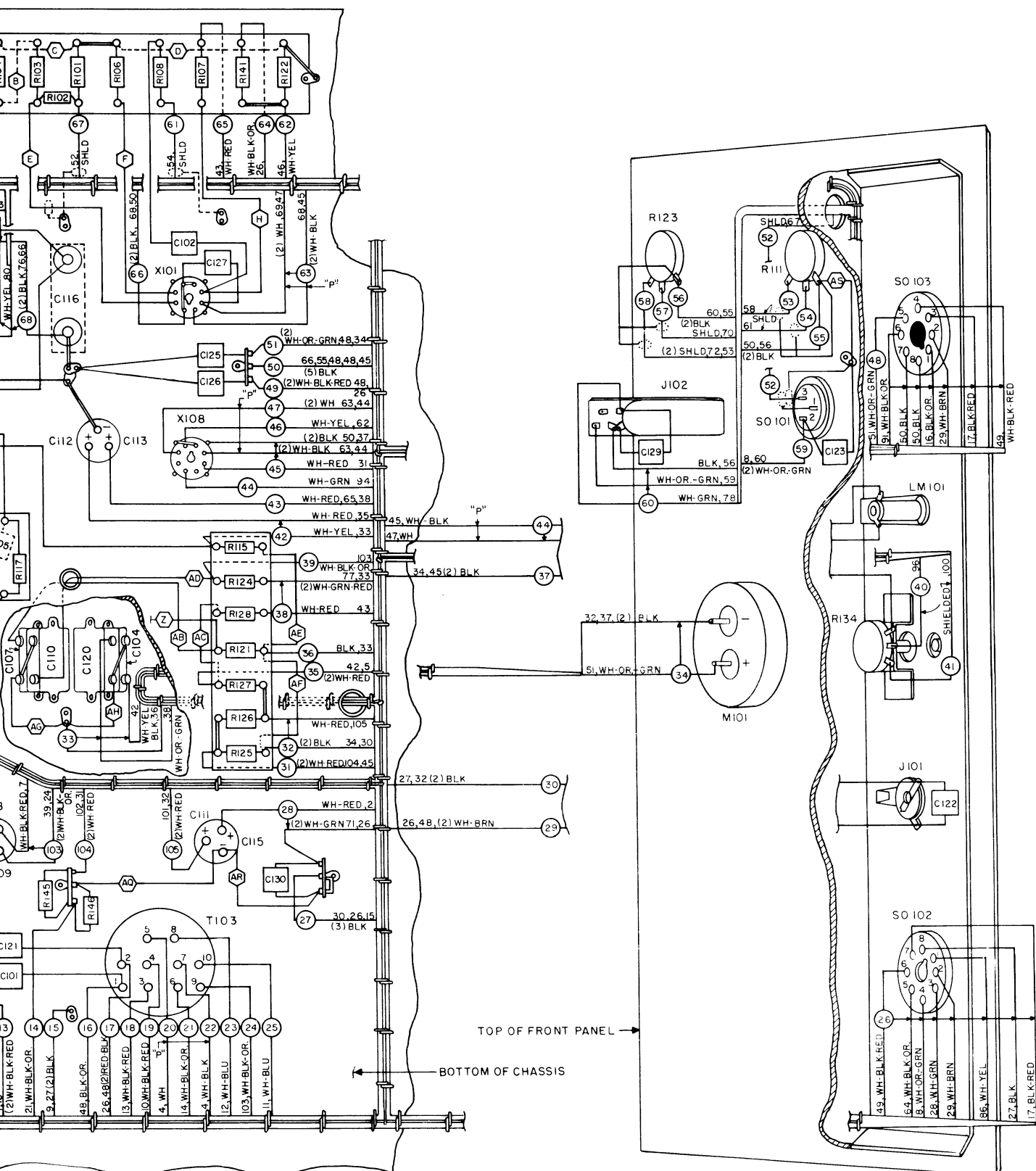

Figure 30. Speech Amplifier BC 6



NOTE

1. (C) CIRCLED LETTERS ARE TO BE PLACED IN THE LACED HOLES.
2. (2) NUMBER OF WIRES IN THE BUNDLE AND NUMBER OF STRIPS IN THE BUNDLE.
3. BARE STRIPS TO BE PLACED IN THE LACED HOLES AND DIRECTION OF STRIP TO BE INDICATED BY AN ARROW.
4. (A) LETTERS IN CIRCLES ARE TO BE PLACED IN THE LACED HOLES AND SHALL BE IN THE SAME POSITION AS SHOWN.
5. (DOTTED LINE) TYPE WIRE TO BE USED. (SOLID LINE) COPPER BARE WIRE TO BE USED.
6. "P" REPRESENTS APPROXIMATE POSITION OF PANEL AND WH-REPRESENTS POSITION OF WIRE. ALL OTHER LETTERS ARE TO BE PLACED IN THE LACED HOLES.
7. RUN WIRE TO BE PLACED IN THE LACED HOLES AND VENIENT TO BE PLACED IN THE LACED HOLES.
8. RUN WIRE TO BE PLACED IN THE LACED HOLES AND VIBRATION TO BE PLACED IN THE LACED HOLES.

NO. 20 AWG

PART	FROM	TERMINAL
C107	(NE)	
C112	(NE)	
C113	(NE)	
C116	GN	S11
C120	(PO)	
C124	GN	S12
C124	GN	S13
C130	GN	S14
R122	GN	S15
T101	3	
T102	4	
T104	2	
X101	1	
X101	4	
X103	3	
X104	3	
X105	3	
X105	1	
X106	3	
X106	4	
X106	5	
X108	1	

Figure 30. Speech Amplifier BC-614-II, wiring diagram of models procured on Order No. 19624.

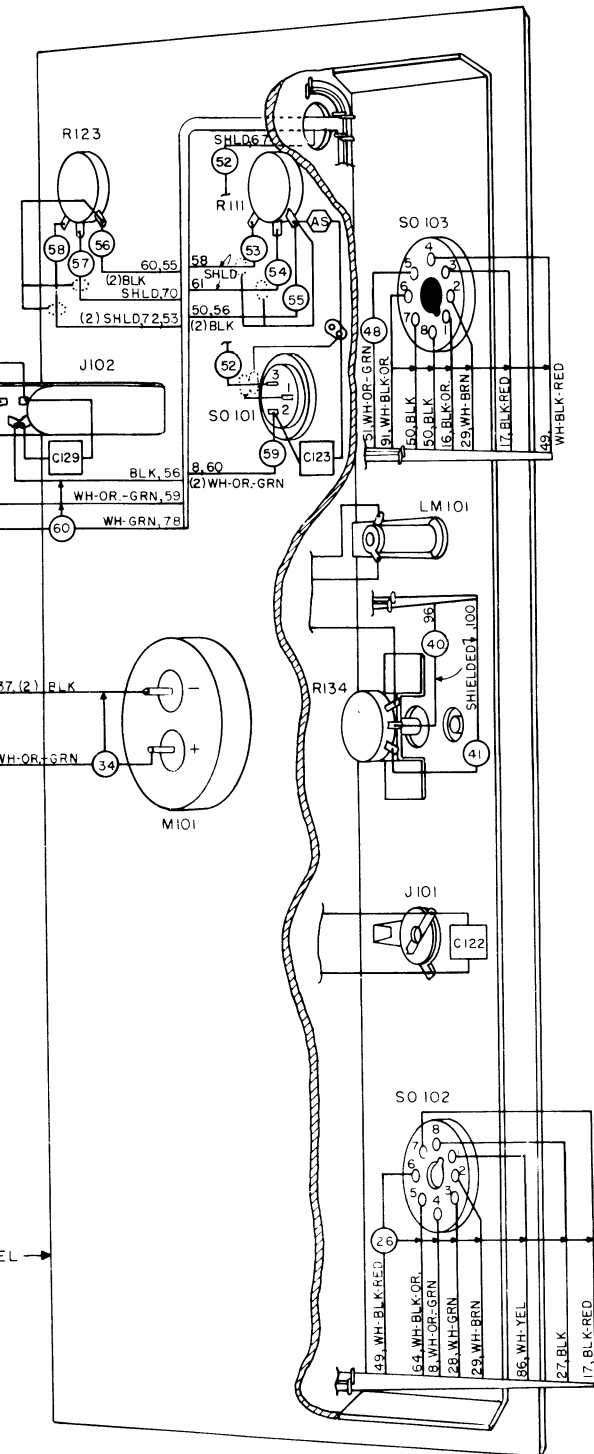

NOTE

1. (1) CIRCLED NUMBERS REPRESENT INDIVIDUAL WIRES OF CABLE. NUMBER NEAR THE LACED PART OF CABLE INDICATES THE STATION TO WHICH THAT WIRE IS RUN.
2. (2) NUMBERS IN PARENTHESIS PRECEDING THE COLOR CODING, INDICATE THE NUMBER OF LIKE WIRES AT THAT STATION.
3. BARE STRAP WIRES, SHOWN AS DOUBLE LINES, SHALL BE NO. 20 AWG RUN AS SHORT AND DIRECT AS POSSIBLE.
4. (A) LETTERS ENCLOSED BY HEXAGON REPRESENT STRANDED JUMPER WIRES AND SHALL BE NO. 22 AWG. SEE TABLE FOR COLOR.
5. (---) DOTTED OUTLINE REPRESENTS SHIELDED WIRE, WHICH SHALL BE WIRE TYPE WL-3/5 (7)-22-C-95, PER SPEC JAN-C-76, COVERED WITH TINNED COPPER BRAID, PER SPEC 94-40229.
6. "P" REPRESENTS PAIRED WIRES IN CABLE, WHICH ARE TWISTED TOGETHER APPROXIMATELY 4 TURNS PER FOOT AND ARE NO. 18 AWG, COLOR CODED WH AND WH-BLK. ALL OTHER WIRES IN THE CABLE ARE NO. 22 AWG.
7. RUN WIRE LOOSE AND DRESSED BACK AGAINST THE CHASSIS IN THE MOST CONVENIENT MANNER.
8. RUN WIRE DIRECTLY FROM TERMINAL TO TERMINAL, IN THE SHORTEST POSSIBLE MANNER, WITH SUFFICIENT SLACK TO PREVENT BREAKAGE UNDER VIBRATION.

NO. 20 AWG BARE STRAP WIRES

FROM PART	TO PART	FROM TERM.	TO TERM.
C107	C110	(NEG)	(POS)
C112	GND LUG	(NEG)	BY C116
C113	GND LUG	(NEG)	BY C112 C113
C116	GND LUG	GND SIDE	BY C112 C113
C120	C104	(POS)	(NEG)
C124	GND LUG	GND SIDE	BY T104
C124	GND LUG	GND SIDE	OFC101 C121
C130	GND LUG	GND SIDE	ON TERM. STRIP
R122	GND LUG UNDER	GND SIDE	MTG SCREW
T101	T101	3	GND
T102	GND LUG	4	BY T102
T104	GND	2	
X101	X101	1	4
X101	X101	4	5
X103	X103	3	6
X104	X104	3	6
X105	R131	3	TOP
X105	GND	1	
X106	X106	3	6
X106	R136	3	TOP
X106	R135	4	TOP
X108	GND	1	

NO. 22 AWG JUMPER WIRES

JUMP	COLOR	NOTE
A	BLK	8
B	WH-GRN	8
C	BLK	8
D	BLK	8
E	SHIELDED	7
F	WH-YEL	8
G	WH-BLU	8
H	WH-BLU	8
J	WH-GRN	8
K	WH-BLU	8
L	BLK	7
M	WH-GRN	8
N	WH-BLU	8
P	WH-BLU	8
Q	WH-BLU	8
R	WH-GRN	8
S	WH-GRN	7
T	WH-BLU	8
U	WH-YEL	8
V	WH-GRN	8
W	WH-BLU	8
X	BLK	7
Y	WH-GRN	8
Z	WH-YEL	8

JUMP	COLOR	NOTE
AA	WH-GRN	8
AB	WH-YEL	7
AC	WH-RED	8
AD	WH-BLK-OR	7
AE	BLK	8
AF	BLK	8
AG	BLK	7
AH	BLK	7
AJ	WH-BLU	7
AK	WH-BLU	7
AL	BLK	8
AM	WH-RED	8
AN	WH-BLU	8
AP	WH-OR-GRN	7
AQ	BLK	7
AR	BLK	7
AS	BLK	7

# APPENDIX I

## REFERENCES

*Note.*—For availability of items listed, check SR 310-20-3, SR 310-20-4, and SR 310-20-5. Check Department of the Army Supply Catalog SIG 1 for Signal Corps Supply Catalog.

---

### 1. Army Regulations

- AR 380-5..... Military Security (Safeguarding Military Information).
- AR 750-5..... Maintenance of Supplies and Equipment (Maintenance Responsibilities and Shop Operation).

### 2. Supply Bulletins

- SB 11-47..... Preparation and Submission of Requisitions for Signal Corps Supplies.
- SB 11-76..... Signal Corps Kit and Materials for Moisture- and Fungi-Resistant Treatment.

### 3. Auxiliary Equipment and Test Equipment

- TM 11-472..... Repair and Calibration of Electrical Measuring Instruments.
- TM 11-2524..... Oscillators I-151-A and I-151-E.
- NAV SHIPS 91272... Oscilloscope OS-8/U.
- TM 11-2624B..... Voltohmmeters, TS-294/U, TS-294B/U, and TS-294C/U.
- TM 11-2626..... Test Unit I-176, I-176-A, and I-176-B.
- TM 11-2627..... Tube Tester I-177 and I-177-A.
- TM 11-2684A..... Audio Oscillator TS-382A/U.
- TM 11-5527..... Multimeter TS-352/U.

### 4. Painting, Preserving, and Lubrication

- TB SIG 13..... Moistureproofing and Fungiproofing Signal Corps Equipment.
- TM 9-2851..... Painting Instructions for Field Use.

### 5. Camouflage, Decontamination, and Demolition

- FM 5-20..... Camouflage, Basic Principles.
- FM 5-25..... Explosives and Demolitions.
- TM 3-220..... Decontamination.

### 6. Other Publications

- FM 24-18..... Field Radio Techniques.
- FM 72-20..... Jungle Warfare.
- SR 310-20-3..... Index of Training Publications.
- SR 310-20-4..... Index of Technical Manuals, Technical Regulations, Technical Bulletins, Supply Bulletins, Lubrication Orders, Modification Work Orders, Tables of Organization and Equipment, Reduction Tables, Tables of Allowances, Tables of Organization, and Tables of Equipment.
- SR 310-20-5..... Index of Administrative Publications.
- SR 700-45-5..... Unsatisfactory Equipment Report (Reports Control Symbol CSGLD-247).

## 6. Other Publications—Continued

SR 745-45-5.....	Report of Damaged or Improper Shipment (Reports Control Symbols
AFR 71-4.....	CSGLD-66 (Army), and AF-MC-U2 (Air Force)).
TB SIG 4.....	Methods for Improving the Effectiveness of Jungle Radio Communication.
TB SIG 25.....	Preventive Maintenance of Power Cords.
TB SIG 66.....	Winter Maintenance of Signal Equipment.
TB SIG 72.....	Tropical Maintenance of Ground Signal Equipment.
TB SIG 75.....	Desert Maintenance of Ground Signal Equipment.
TB SIG 123.....	Preventive Maintenance Practices for Ground Signal Equipment.
TB SIG 178.....	Preventive Maintenance Guide for Radio Communication Equipment.
TB SIG 219.....	Operation of Signal Equipment at Low Temperatures.
TB SIG 223.....	Field Expedients for Wire and Radio.
TM 11-453.....	Shop Work.
TM 11-455.....	Radio Fundamentals.
TM 11-466.....	Radar Electronic Fundamentals.
TM 11-483.....	Suppression of Radio Noises.
TM 11-486.....	Electrical Communication Systems Engineering.
TM 11-624.....	Radio Set AN/MRC-2 and 2A.
TM 11-661.....	Electrical Fundamentals (Direct Current).
TM 11-681.....	Electrical Fundamentals (Alternating Current).
TM 11-4000.....	Trouble Shooting and Repair of Radio Equipment.

## APPENDIX II

### IDENTIFICATION TABLE OF PARTS

#### 1. Requisitioning Parts

The fact that a part is listed in this table is not sufficient basis for requisitioning the item. Requisitions must cite an authorized basis, such as a specific T/O&E, T/A, SIG 7 & 8, list of allowances of expendable material, or another authorized supply basis. The Department of the Army Supply Catalog applicable to the equipment covered in this manual is SIG 7 & 8-BC-614. For an index of available supply catalogs in the Signal portion of the Department of the Army Supply Catalog, see the latest issue of SIG 1.

#### 2. Identification Table of Parts for Speech Amplifier BC-614-E, -H, and -I

Ref symbol	Model			Name of part and description	Function of part	Signal Corps stock No.
	E	H	I			
	(*)			SPEECH AMPLIFIER BC-614-E: approx 2 w peak output; 115 v ac, 60 cyc, single ph, 15 amp; 3 input channels, one low-impedance for Microphone T-17 or T-30, one medium-impedance for Telephone EE-8, one high-impedance for Microphone T-50; output impedance 500 ohms; metal cabinet.	Raises microphone output for voice modulation of transmitter.	2C214E.
		(*)	(*)	SPEECH AMPLIFIER BC-614-H, -I: .5 w output rating; freq response $\pm 1$ db, 200-300 cps; input 115 v, 60 cyc, single ph; input impedance 200 ohms, 1 meg; output impedance 500 ohms; 16 $\frac{1}{2}$ " lg x 9 $\frac{3}{4}$ " d x 9 $\frac{1}{2}$ " h incl shock mounts; US Army spec #71-1683-A.	do	2C214-H.
	(*)	(*)	(*)	TECHNICAL MANUAL TM#11-5054.		Order through AGO.
M101	(*)			AMMETER, DC: 0-300 ma; round phenolic flush mtg case; escutcheon 3 $\frac{1}{16}$ " sq x $\frac{7}{32}$ " thk; case 1 $\frac{5}{8}$ " d x 2.8" dia; JAN type MR34W300DCMA.	Indicates plate and grid current drawn by modulator tubes in transmitter.	3F930-32.
M101		(*)	(*)	AMMETER, DC: 0-300 ma; JAN type MR26W300DCMA.	Same as M101 above	3F930-40.
C117, C118, C122, C123, C128.	(*)			CAPACITOR, fixed: paper; JAN type CM30B202J; 2,000 $\mu$ mf $\pm 5\%$ ; 500 vdw; max body dimen 5 $\frac{3}{4}$ " lg x 5 $\frac{3}{4}$ " wd x $\frac{9}{32}$ " thk.	C117, C118: Plate to grid coupling, V106. C122: R-f bypass across jack J101. C123: R-f bypass across connector SO-101. C128: Cathode a-f bypass of V106.	3K302022



## 2. Identification Table of Parts for Speech Amplifier BC-614-E, -H, and -I—Continued

Ref symbol	Model			Name of part and description	Function of part	Signal Corps stock No.
	E	H	I			
C 117, C 118, C 122, C 123, C 128.	----	(*)	(*)	CAPACITOR, fixed: paper dielectric; 2,000 $\mu\mu\text{f}$ $\pm 20\%$ ; 100 vdew; JAN type CN42E202M.	Same as C117, C118, C122, C123, and C128 above.	3DA2-202
C 127, C 129, C 130.	----	(*)	(*)	CAPACITOR, fixed: mica dielectric; 4,700 $\mu\mu\text{f}$ $\pm 10\%$ ; 500 vdew; JAN type CM35B472K; (I model has 5,100 $\mu\mu\text{f}$ in equipment.)	C127: R-f bypass; filament to ground of V101. C129: R-f bypass across jack J102. C130: R-f filter at input of telephone line.	3K3547221
C 127, C 129, C 130.	----	(*)	----	CAPACITOR, fixed: mica; JAN type CM35B512J; 5,100 $\mu\mu\text{f}$ $\pm 5\%$ ; 500 vdew; max body dimen $5\frac{3}{4}$ " lg x $5\frac{3}{4}$ " wd x $1\frac{1}{2}$ " thk.	Same as C127, C129, and C130 above.	3K3551222
C 101, C 102, C 103, C 105, C 106, C 114, C 119, C 121, C 125, C 126.	----	(*)	----	CAPACITOR, fixed: paper; JAN type CN42A103M; .01 $\mu\text{f}$ $\pm 20\%$ ; 600 vdew; $1\frac{5}{32}$ " lg x $9\frac{1}{4}$ " x $1\frac{1}{2}$ ".	C101: A-f bypass of 115-volt line input. C102: Couples plate of V101 to gain control R111. C103: Couples plate of V102 to grid (pin 1) of V103. C105, C106: Couples plate of V103 to grids of V104. C114: Couples plate of V105 to primary of T104. C119: Couples control R123 to grid of V102. C121: A-f bypass of 115-volt line input. C125: A-f bypass across metal M101. C126: A-f bypass from pin 6 of SO-102 to ground.	3DA10-389
C 101, C 102, C 103, C 105, C 106, C 114, C 119, C 121, C 125, C 126.	----	(*)	(*)	CAPACITOR, fixed; paper dielectric; .01 $\mu\text{f}$ $\pm 20\%$ ; 600 vdew; JAN type CN35A103M; ea.	Same as C101, C102, C103, C105, C106, C114, C119, C121, C125, and C126 above.	3DA10-367
C116, C124	----	(*)	----	CAPACITOR, fixed: paper; .35 $\mu\text{f}$ $\pm 10\%$ ; 400 vdew; $1\frac{3}{4}$ " lg x 1" wd x $1\frac{3}{16}$ " thk; oil-filled; Ineco #7446; Hallicrafters part/dwg #41A016.	C116: Time constant capacitor of limiter rectifier diode load. C124: Bypass across control circuit of connector SO-101, J102, and SO-102; prevents sparking across microphone switch contacts.	3DA350-5
C116, C124	----	(*)	(*)	CAPACITOR, fixed: paper dielectric; .35 $\mu\text{f}$ $\pm 10\%$ ; 600 vdew; $1\frac{3}{16}$ " lg x 1" wd x $\frac{7}{8}$ " h; Dubilier type DYRB6035J; (I model has .25 $\mu\text{f}$ in equipment.)	Same as C116 and C124 above.	3DA350-12

## 2. Identification Table of Parts for Speech Amplifier BC-614-E, -H, and -I—Continued

Ref symbol	Model			Name of part and description	Function of part	Signal Corps stock No.
	E	H	I			
C108, C109, C111, C112, C113, C115.	(*)			CAPACITOR, fixed: electrolytic; JAN type CE32F100R; 2 sect.; 10-10 $\mu$ f; 450 vdew; 2 $\frac{1}{4}$ " lg x 1 $\frac{3}{8}$ " dia.	C108: Input filter capacitor of h-v supply. C109: Output filter capacitor of h-v supply. C111: Decoupling filter capacitor for tube V103. C112: Decoupling filter capacitor for tube V102. C113: Decoupling filter capacitor for tube V101. C115: Decoupling filter capacitor for tube V105.	3DB10-177
C108, C109, C111, C112, C113, C115.		(*)	(*)	CAPACITOR, fixed: electrolytic; 2 sect.; 10 $\mu$ f ea sect.; 450 vdew; JAN type CE42F100R.	Same as C108, C109, C111, C112, C113, and C115 above.	3DB10-168
C104, C107		(*)	(*)	CAPACITOR, fixed: electrolytic; 10 $\mu$ f, 300 vdew; JAN type CE63C100N.	C104: Cathode bypass for V103. C107: Cathode bypass for V104.	3DB10-190
C104, C107, C110, C120.	(*)			CAPACITOR, fixed: electrolytic; 4 sect.; 10-10-30-30 $\mu$ f + 75% - 10%; 25 vdew; Incco #1B99; Hallcrafters part/dwg #42A049.	C104, C107: Same as C104 and C107 above. C110, C120: Filter capacitors for carbon microphone d-c supply.	3DB10-21
C110, C120		(*)	(*)	CAPACITOR, fixed: electrolytic, 50 $\mu$ f, 50 vdew; JAN type CE63C500G.		3DB50-78
SO-101	(*)			CONNECTOR, female contact: 3 round cont; straight; $\frac{1}{16}$ " d; thd $\frac{1}{16}$ " -28 at one end; Amphenol #PC3F; Hallcrafters part/dwg #10A046.	Receives dynamic microphone plug-in input circuit.	2Z8658
SO-101		(*)	(*)	CONNECTOR, receptacle: female cont; 3 rd pol cont; straight; $\frac{1}{16}$ " lg x 1 $\frac{1}{8}$ " dia o/a; Amphenol part #91-PC3F.	Same as SO-101 above	2Z3064-123
SO-102	(*)	(*)	(*)	CONNECTOR, receptacle: female cont; 8 rd pol cont; straight; 1" lg x 1 $\frac{3}{4}$ " dia o/a; Amphenol type #79P08F.	Receives cord from control or junction box.	2Z8678.13
SO-103	(*)	(*)	(*)	CONNECTOR, receptacle: male cont; 8 rd cont; straight type; 1 $\frac{1}{8}$ " lg x 1 $\frac{1}{4}$ " d o/a; Amphenol type #79-P08M.	Receives cord from transmitter.	2Z7118.20
	(*)	(*)	(*)	DIAL, control: disk type; black bakelite knob; round; 1 $\frac{1}{2}$ " dia x $\frac{7}{8}$ " d o/a; B&W part #27-47.	Control knobs for input level of dynamic and carbon microphones.	2Z5849.11
V102, V108	(*)	(*)	(*)	ELECTRON TUBE: type 6J5	V102: Second audio amplifier. V108: Sidetone buffer.	2J6J5.
V103, V104, V106.	(*)	(*)	(*)	ELECTRON TUBE: type 6SN7GT.	V103: Third audio amplifier and phase inverter. V104: Fourth audio amplifier. V106: Sidetone oscillator.	2J6SN7GT
V101	(*)	(*)	(*)	ELECTRON TUBE: type 6SQ7	First audio amplifier	2J6SQ7
V105	(*)	(*)	(*)	ELECTRON TUBE: type 6SR7	Modulation limiter	2J6SR7.
V107	(*)	(*)	(*)	ELECTRON TUBE: type 80	Power supply rectifier	2J80

## 2. Identification Table of Parts for Speech Amplifier BC-614-E, -H, and -I—Continued

Ref symbol	Model			Name of part and description	Function of part	Signal Corps stock No.
	E	H	I			
J101	(*)			JACK, telephone: for 2 cond .25'' dia plug; 1¼'' lg x 1'' dia; Utahrad #2A; Hallicrafters part/dwg #36A002.	Receives telegraph key	2Z5598-13
J101	(*)	(*)		JACK, telephone: for 2 cond .250'' dia plug; approx 1¼'' lg x 1'' wd x ¾'' h; JAN type JJ-034.	Same as J101 above	2Z5534
J102	(*)			JACK JK-22: telephone; for 3 cond ¼'' dia plug; 3 <sup>23</sup> / <sub>64</sub> '' lg x 1 <sup>3</sup> / <sub>16</sub> '' wd x 9/ <sub>16</sub> '' thk o/a.	Receives carbon microphone plug.	2Z5522
J102	(*)	(*)		JACK, telephone: for 3 cond plug .2085'' dia x 1.093'' lg; JAN type JJ-083.	Same as J102 above	2Z5598A-83
E106	(*)	(*)		LAMP LM-27: incandescent; clear; 6-8 v, .25 amp; 1 <sup>3</sup> / <sub>16</sub> '' lg o/a; miniature bayonet base; DeVry part/dwg #400.	Panel bulb for indicating presence of primary power to speech amplifier.	2Z5927
LM101	(*)			LAMP LM-27: incandescent; clear; 6-8 v, .25 amp; 1 <sup>3</sup> / <sub>16</sub> '' lg o/a; miniature bayonet base; DeVry part/dwg #400.	Same as E106 above	2Z5927
	(*)			LIGHT, indicator: w/red jewel; miniature bayonet base; incl horiz mtg and 2 soldering lugs; RCA #5147K.	Filament on-off indicator	2Z5991-4
I-101	(*)	(*)		LIGHT, indicator: w/lens; miniature bayonet base; 1¾'' lg x 1'' d o/a; Dialco part #810B-431.	Panel light bracket with socket and lens to hold power on indicator lamp.	2Z5991-160
A101 through A104	(*)			MOUNT, shock: metal; 16 <sup>7</sup> / <sub>8</sub> '' lg x 9 <sup>3</sup> / <sub>4</sub> '' wd.	Protect speech amplifier against excessive vibration.	2Z8500-2
A104	(*)	(*)		MOUNT, vibration: sq mtg; 2 <sup>3</sup> / <sub>8</sub> '' lg x 2 <sup>3</sup> / <sub>8</sub> '' wd x 1.063'' h o/a; Lord part #153-PC-24.		2Z8405-49
CH101	(*)			REACTOR: filter choke; 29 hy; 2 ma, 662 ohms; 2'' lg x 3 <sup>3</sup> / <sub>8</sub> '' h x 2 <sup>9</sup> / <sub>16</sub> '' d o/a; Gentrans #1C-103; Hallicrafters part/dwg #56B014.	Smoothing choke, part of pi-filter of h-v power rectifier.	3C548
CH101	(*)	(*)		REACTOR: filter choke; 1 wnd 29 hy ind, 25 ma dc; HS metal case; 2 <sup>3</sup> / <sub>8</sub> '' h x 3 <sup>3</sup> / <sub>16</sub> '' lg x 2 <sup>1</sup> / <sub>2</sub> '' w; Chi Transf part #14567-0.	Same as CH101 above	3C547-29
R142	(*)			RESISTOR, fixed: comp; 51 ohms ±5%; 1 w; JAN type RC30BF510J.	Limits dc through carbon microphone.	3RC30BF510J
R104	(*)	(*)		RESISTOR, fixed: comp; 100 ohms ±10%; ½ w; JAN type RC20BF101K.	Part of telephone input voltage divider network.	3RC20BF101K
R104	(*)			RESISTOR, fixed: comp; JAN type RC21BF101K; 100 ohms ±10%; ½ w; max body dimen .655'' lg x .249'' dia.	Same as R104 above	3RC21BF101K
R142		(*)		RESISTOR, fixed: comp; 200 ohms ±5%; 1 w; JAN type RC30BF201J.	Limits dc through carbon microphone.	3RC30BF201J

## 2. Identification Table of Parts for Speech Amplifier BC-614-E, -H, and -I—Continued

Ref symbol	Model			Name of part and description	Function of part	Signal Corps stock No.
	E	H	I			
R142	(*)			RESISTOR, fixed: comp; JAN type RC31BF201J; 200 ohms $\pm 5\%$ ; 1 w; max body dimen 1.28" lg x .310" dia.	Same as R142 above	3RC31BF201J
R124	(*)			RESISTOR, fixed: wire-wound; JAN type RU4C301J; 300 ohms $\pm 5\%$ ; 1 w; max dimen 1 $\frac{1}{2}$ " lg x $\frac{1}{2}$ " dia.	Part of carbon microphone d-c filter network.	3RU30001
R124		(*)	(*)	RESISTOR, fixed: comp; 330 ohms $\pm 10\%$ ; 1 w; JAN type RC30BF331K.	Same as R124 above	3RC30BF331K
R115, R121		(*)	(*)	RESISTOR, fixed: comp; 470 ohms $\pm 10\%$ ; 1 w; JAN type RC30BF471K.	R115: Cathode bias for V103. R121: Cathode bias for V104.	3RC30BF471K
R115, R121	(*)			RESISTOR, fixed: wire-wound; JAN type RU4C511J; 510 ohms $\pm 5\%$ ; 1 w; max dimen 1 $\frac{1}{2}$ " lg x $\frac{1}{2}$ " dia.	Same as R115 and R121 above	3RU32401
R136		(*)	(*)	RESISTOR, fixed: comp; 510 ohms $\pm 5\%$ ; $\frac{1}{2}$ w; JAN type RC20BF511J.	Cathode bias for sidetone oscillator.	3RC20BF511J
R136	(*)			RESISTOR, fixed: comp; JAN type RC21BF511J; 510 ohms $\pm 5\%$ ; $\frac{1}{2}$ w; max body dimen .655" lg x .249" dia.	Same as R136 above	3RC21BF511J
R112, R131		(*)	(*)	RESISTOR, fixed: comp; 1,000 ohms $\pm 10\%$ ; $\frac{1}{2}$ w; JAN type RC20BF102K.	R112: Cathode bias of V102. R131: Cathode bias of V105.	3RC20BF102K
R106, R112, R131.	(*)			RESISTOR, fixed: comp; JAN type RC21BF102K; 1,000 ohms $\pm 10\%$ ; $\frac{1}{2}$ w; max body dimen .655" lg x .249" dia.	R112, R131: Same as R112 and R131 above. R106: Cathode bias of V101.	3RC21BF102K
R122	(*)			RESISTOR, fixed: comp; JAN type RC21BF202J; 2,000 ohms $\pm 5\%$ ; $\frac{1}{2}$ w; max body dimen .655" lg x .249" dia.	Cathode bias of V108	3RC21BF202J
R122		(*)	(*)	RESISTOR, fixed: comp; 2,200 ohms $\pm 10\%$ ; $\frac{1}{2}$ w; JAN type RC20BF222K.	Same as R122 above	3RC20BF222K
R106, R139, R140, R141.		(*)	(*)	RESISTOR, fixed: comp; 4,700 ohms $\pm 10\%$ ; $\frac{1}{2}$ w; JAN type RC20BF472K.	R106: Cathode bias of V101. R139, R140: Plate loads of V106. R141: Current limiter, V108.	3RC20BF472K
R139, R140, R141.	(*)			RESISTOR, fixed: comp; JAN type RC21BF512J; 5,100 ohms $\pm 5\%$ ; $\frac{1}{2}$ w; max body dimen .655" lg x .249" dia.		3RC21BF512J
R146		(*)	(*)	RESISTOR, fixed: comp; 6,800 ohms $\pm 10\%$ ; $\frac{1}{2}$ w; JAN type RC20BF682K.	Part of voltage divider in rectifier circuit; used for hum reduction.	3RC20BF682K
R129	(*)			RESISTOR, fixed: comp; JAN type RC21BF203J; 20,000 ohms $\pm 5\%$ ; $\frac{1}{2}$ w; max body dimen .655" lg x .249" dia.	Plate voltage dropping, V105	3RC21BF203J
R129		(*)	(*)	RESISTOR, fixed; comp; 22,000 ohms $\pm 10\%$ ; $\frac{1}{2}$ w; JAN type RC20BF223K.	Same as R129 above	3RC20BF223K

## 2. Identification Table of Parts for Speech Amplifier BC-614-E, -H, and -I—Continued

Ref symbol	Model			Name of part and description	Function of part	Signal Corps stock No.
	E	H	I			
R126.....	(*)			RESISTOR, fixed: comp; JAN type RC41BF203J; 20,000 ohms $\pm 5\%$ ; 2 w; max body dimen 1.78" lg x .405" dia.	V103 plate circuit decoupling..	3RC41BF203J
R126.....		(*)	(*)	RESISTOR, fixed: comp; 22,000 ohms $\pm 10\%$ ; 2 w; JAN type RC41BF223K.	Same as R126 above.....	3RC41BF223K
R105.....		(*)	(*)	RESISTOR, fixed: comp; 27,000 ohms $\pm 5\%$ ; $\frac{1}{2}$ w; JAN type RC20BF273J.	Part of telephone input voltage divider network.	3RC20BF273J
R105.....	(*)			RESISTOR, fixed: comp; JAN type RC21BF273K; 27,000 ohms $\pm 10\%$ ; $\frac{1}{2}$ w; max body dimen .655" lg x .249" dia.	Same as R105 above.....	3RC21BF273K
R130, R138.....		(*)	(*)	RESISTOR, fixed: comp; 47,000 ohms $\pm 10\%$ ; $\frac{1}{2}$ w; JAN type RC20BF473K.	R130: Plate load resistor of V105. R138: Part of voltage divider for output of sidetone oscillator.	3RC20BF473K
R127, R128.....		(*)	(*)	RESISTOR, fixed: comp; 47,000 ohms $\pm 10\%$ ; 1 w; JAN type RC30BF473K.	R127: V102 plate circuit decoupling. R128: V101 plate circuit decoupling.	3RC30BF473K
R130.....	(*)			RESISTOR, fixed: comp; JAN type RC21BF513J; 51,000 ohms $\pm 5\%$ ; $\frac{1}{2}$ w; max body dimen .655" lg x .249" dia.	Same as R130 above.....	3RC21BF513J
R127, R128, R138.	(*)			RESISTOR, fixed: comp; JAN type RC31BF513J; 51,000 ohms $\pm 5\%$ ; 1 w; max body dimen 1.28" lg x .310" dia; (R138 used in model "E" above serial #1150).	Same as R127, R128, and R138 above.	3RC31BF513J
R125.....	(*)	(*)	(*)	RESISTOR, fixed: comp; 75,000 ohms $\pm 5\%$ ; 2 w; JAN type RC41BF753J.	Bleeder across h-v to ground..	3RC41BF753J
R103, R107, R113, R116, R117.		(*)	(*)	RESISTOR, fixed: comp; 100,000 ohms $\pm 10\%$ ; $\frac{1}{2}$ w; JAN type RC20BF104K.	R103: Part of impedance-matching network in grid circuit of V101. R107: Plate load of V101. R113: Plate load of V102. R116: Plate load of V103 (pin 5). R117: Plate load of V103 (pin 2).	3RC20BF104K
R103, R107, R113, R116, R117, R138.	(*)			RESISTOR, fixed: comp; JAN type RC21BF104K; 100,000 ohms $\pm 10\%$ ; $\frac{1}{2}$ w; max dimen .655" lg x .249" dia; (R138 used in model "E" below serial #1151).	R103: Part of impedance-matching network in grid circuit of V101. R107: Plate load of V101. R113: Plate load of V102. R116: Plate load of V103 (pin 5). R117: Plate load of V103 (pin 2). R138: Part of voltage divider for output of sidetone oscillator.	3RC21BF104K

## 2. Identification Table of Parts for Speech Amplifier BC-614-E, -H, and -I—Continued

Ref symbol	Model			Name of part and description	Function of part	Signal Corps stock No.
	E	H	I			
R108.....	(*)			RESISTOR, fixed: comp; JAN type RC21BF204J; 200,000 ohms $\pm 5\%$ ; $\frac{1}{2}$ w; max body dimen .655" lg x .249" dia.	R108: Provides more uniform a-c load for V101.	3RC21BF204J
R108, R145.....	(*)	(*)		RESISTOR, fixed: comp; 220,000 ohms $\pm 10\%$ ; $\frac{1}{2}$ w; JAN type RC20BF224K.	R108: Same as R108 above... R145: Part of voltage divider in rectifier circuit; for hum reduction.	3RC20BF224K
R110, R114, R118, R119, R120, R135.....	(*)			RESISTOR, fixed: comp; JAN type RC21BF244J; 240,000 ohms $\pm 5\%$ ; $\frac{1}{2}$ w; max body dimen .655" lg x .249" dia.	R110: Isolating resistor between T101 and R123. R114: Grid (pin 1) return of V103. R118: Grid (pin 4) return of V104. R119: Grid (pin 1) return of V104. R120: Balancing leg of phase inverter circuit. R135: Grid (pin 4) return of V106 (pin 1 in, E model).	3RC21BF244J
R110, R114, R118, R119, R120, R135.....	(*)	(*)		RESISTOR, fixed: comp; 270,000 ohms $\pm 10\%$ ; $\frac{1}{2}$ w; JAN type RC20BF274K.	Same as R110, R114, R118, R119, R120, and R135.	3RC20BF274K
R109, R132.....	(*)			RESISTOR, fixed: comp; JAN type RC21BF514J; 510,000 ohms $\pm 5\%$ ; $\frac{1}{2}$ w; max body dimen .655" lg x .249" dia.	R109: D-c grid return of V102 to limiter V105. R132: Part of time-constant r-c filter of limiter rectifier circuit.	3RC21BF514J
	(*)	(*)		RESISTOR, fixed: comp; 560,000 ohms $\pm 10\%$ ; $\frac{1}{2}$ w; JAN type RC20BF564K.	Same as R109 and R132.....	3RC20BF564K
R101.....	(*)	(*)		RESISTOR, fixed: comp; 1 meg; $\pm 10\%$ ; $\frac{1}{2}$ w; JAN type RC20BF105K.	Grid return of V101 and part of impedance-matching network in grid circuit of V101.	3RC20BF105K
R101.....	(*)			RESISTOR, fixed: comp; JAN type RC21BF105K; 1 meg $\pm 10\%$ ; $\frac{1}{2}$ w; max body dimen .655" lg x .249" dia.	Same as R101 above.....	3RC21BF105K
R102, R133.....	(*)			RESISTOR, fixed: comp; JAN type RC21BF305J; 3 meg $\pm 5\%$ ; $\frac{1}{2}$ w; max body dimen .655" lg x .249" dia.	R102: Grid return and part of impedance-matching network in grid circuit of V101. R133: Diode load for V105.	3RC21BF305J
R102, R133.....	(*)	(*)		RESISTOR, fixed: comp; 3.3 meg $\pm 5\%$ ; $\frac{1}{2}$ w; JAN type RC20BF335J.	Same as R102 and R133 above.	3RC20BF335J
R137.....	(*)			RESISTOR, variable (potentiometer): carbon; 100,000 ohms $\pm 20\%$ ; $\frac{1}{4}$ w; $1\frac{1}{16}$ " dia x $\frac{3}{16}$ " d; shaft $\frac{1}{4}$ " dia x $\frac{1}{8}$ " lg; Centralab splc per Hallicrafters part/dwg #25C089G.	Sidetone volume control.....	2Z7271-31
R137.....	(*)	(*)		RESISTOR, variable: comp; 100,000 ohms $\pm 10\%$ ; 2 w; JAN type RV4APSD104C.	Same as R137 above.....	3RV51032

## 2. Identification Table of Parts for Speech Amplifier BC-614-E, -H, and -I—Continued

Ref symbol	Model			Name of part and description	Function of part	Signal Corps stock No.
	E	H	I			
R134-----	(*)			RESISTOR, variable (potentiometer): carbon; 500,000 ohms $\pm 20\%$ ; $\frac{1}{4}$ w; $1\frac{1}{16}$ " dia x $\frac{1}{2}$ " d; shaft $\frac{1}{4}$ " dia x $\frac{1}{8}$ " lg; Centralab #1-010-1603; Hallicrafters part/dwg #25C038G.	Modulation limiter control-----	2Z7298-4
R134-----		(*)	(*)	RESISTOR, variable: comp; 500,000 ohms $\pm 10\%$ ; 2 w; JAN type RV4APSD504C.	Same as R134 above-----	3RV55044
R111, R123-----	(*)			RESISTOR, variable (potentiometer): carbon; 1 meg $\pm 20\%$ ; 1 w; $1\frac{1}{16}$ " dia x $\frac{3}{16}$ " d; shaft $\frac{1}{4}$ " dia x $\frac{3}{8}$ " lg; Centralab #1-101-1602; Hallicrafters part/dwg #25CO43G.	R111: Volume control for dynamic mike and telephone. R123: Volume control for carbon mike.	2Z7298-3
R111, R123-----		(*)	(*)	RESISTOR, variable: comp; 1 meg $\pm 20\%$ ; 2 w; JAN type RV4APSD105D.	Same as R111 and R123 above.	3RV61026
H102-----		(*)		RETAINER, electron tube: accom $1\frac{3}{8}$ " dia tube; $1\frac{3}{4}$ " dia x $\frac{5}{8}$ " h o/a; Mallory type #VR-3.	Prevents removal, as result of vibration, of tube V107 from socket.	2Z2626.2
H102A-----			(*)	RETAINER, electron tube: accom tubes w/ $1\frac{3}{4}$ " max dia crown and $2\frac{5}{16}$ " max dia body; $2\frac{9}{16}$ " lg x $2\frac{1}{8}$ " dia x $\frac{3}{4}$ " dia hole; Times Facsimile part #4 hat.	Same as H102-----	2Z2643.138
			(*)	SOCKET, tube: std 4 cont; molded black bakelite; $1\frac{3}{4}$ " lg x $1\frac{1}{32}$ " wd x $\frac{7}{8}$ " d o/a; Amphenol #MIP-4.	Tube socket for V107-----	2Z8654.1
X107-----		(*)	(*)	SOCKET, electron tube: 4 med cont; mtg plate molded into body; $1\frac{7}{8}$ " lg x $1\frac{9}{32}$ " wd x $1\frac{1}{32}$ " d; Amphenol type #77-MIP-4TM.	Tube socket for V107-----	2Z8674.84
			(*)	SOCKET, tube: std octal; molded black bakelite; $1\frac{3}{4}$ " lg x $1\frac{1}{32}$ " wd x $\frac{7}{8}$ " d o/a; Amphenol #MIP-8.	Tube sockets for tubes V101 through V106, and V108, respectively.	2Z8659-6
X101 through X106, X108		(*)	(*)	SOCKET, electron tube: 8 med cont; one-piece saddle mtg; $1\frac{13}{16}$ " lg x $1\frac{3}{8}$ " wd x $\frac{1}{4}$ " h o/a; JAN type TS101P02.	Tube sockets for tubes V101 through V106, and V108, respectively.	2Z8678.326
H101-----	(*)	(*)	(*)	STUD: cowl fastener type; $\frac{9}{16}$ " dia x $1\frac{1}{32}$ " wd x $\frac{31}{32}$ " lg o/a; Shakeproof #98-OW-5-15.	Fastens front panel and chassis assembly to cabinet.	6LK987.13
H102B-----			(*)	STUD, threaded: support for tube retainer; $\frac{5}{32}$ -32 NC-2 thd; $\frac{3}{4}$ " lg o/a; Times Facsimile part #32 post.	Supports H102A-----	2Z6820.368
E101-----		(*)	(*)	TERMINAL BOARD: general purpose; 8 solder term.; $2\frac{1}{4}$ " lg x $1\frac{1}{2}$ " wd x $\frac{1}{16}$ " thk; B&W part/dwg #S27-533-1C.	Mounts resistors R116 through R120.	3Z770-8.75

## 2. Identification Table of Parts for Speech Amplifier BC-614-E, -H, and -I—Continued

Ref symbol	Model			Name of part and description	Function of part	Signal Corps stock No.
	E	H	I			
E102		(*)	(*)	TERMINAL BOARD: general purpose; 10 solder term.; $2\frac{3}{4}$ " lg x $1\frac{1}{2}$ " wd x $\frac{1}{16}$ " thk; B&W part/dwg #S27-532-1C.	Mounts resistors R129 through R133.	3Z770-10.49
E103		(*)		TERMINAL BOARD: general purpose; 14 solder term.; $3\frac{1}{8}$ " lg x $2\frac{3}{8}$ " wd x $\frac{1}{16}$ " thk; B&W part/dwg #S27-534-1C.	Mounts resistors R115, R121, R124 through R128, and R145 and R146. (In some H models, R145 and R146 are mounted elsewhere.)	3Z770-14.55
E103			(*)	TERMINAL BOARD: resistor mtg; 18 turret term.; $3\frac{7}{16}$ " lg x $2\frac{3}{8}$ " wd x $\frac{7}{16}$ " thk o/a; Hallcrafters part/dwg #88B808.	Same as E103 above	3Z770-18.69
E104		(*)	(*)	TERMINAL BOARD: general purpose; 14 solder term.; $4\frac{3}{4}$ " lg x $1\frac{1}{2}$ " wd x $\frac{1}{16}$ " thk; B&W part/dwg #S27-531-1C.	Mounts resistors R135, R136, R138 through R140, and capacitors C117 and C118.	3Z770-14.56
E105		(*)	(*)	TERMINAL BOARD: general purpose; 28 solder term.; $7\frac{1}{4}$ " lg x $1\frac{1}{2}$ " wd x $\frac{1}{16}$ " thk; B&W part/dwg #S27-530-1C.	Mounts resistors R101 through R108, R110, R112 through R114, and R141.	3Z770-28.19
T101	(*)			TRANSFORMER, AF: microphone; pri 200 ohms, sec 200 ohms; upright shielded; 2" lg x $2\frac{1}{16}$ " wd x $3\frac{5}{16}$ " h o/a; Gentrans #2D-131; Hallcrafters part/dwg #55A035.	Couples carbon microphone to grid of V102.	2Z9631.3
T101		(*)	(*)	TRANSFORMER, AF: input type; pri impedance 200 ohms, sec 200 ohms; HS metal case; $1\frac{1}{2}$ " lg x $1\frac{1}{2}$ " wd x $2\frac{1}{8}$ " h o/a; Chi Transf part #14568A.	Same as T101 above	2Z9631.405
T102	(*)			TRANSFORMER, AF: output; pri to match 18,000 ohms push-pull 6SN7 plates; sec to match 500-ohm line; upright shielded; $2\frac{7}{16}$ " lg x 2" wd x $2\frac{7}{8}$ " h less term.; Gentrans #2A151; Hallcrafters part/dwg #55B069.	Couples push-pull plates of output tube V104 to 500-ohm line.	2Z9632.413
T102		(*)	(*)	TRANSFORMER, AF: plate coupling type; pri impedance 18,000 ohms, sec 500 ohms CT; HS steel case; 2.230" lg x $2\frac{3}{32}$ " wd x $2\frac{5}{8}$ " h o/a; Chi Transf part #14570A.	Same as T102 above	2Z9632.600
T103	(*)			TRANSFORMER, power: plate and fil; pri 117 v 50/60 cyc; sec #1, 500 v, CT, 25 ma; sec #2, 6.3 v, CT, 3.25 amp; sec #3, 5 v, 2 amp; HS; 3" lg x $3\frac{1}{4}$ " wd x $4\frac{1}{8}$ " h; Gentrans #5C192.	Supplies all filament power and hv to rectifier of power supply.	2Z9613.2



## 2. Identification Table of Parts for Speech Amplifier BC-614-E, -H, and -I—Continued

Ref symbol	Model			Name of part and description	Function of part	Signal Corps stock No.
	E	H	I			
T103-----		(*)	(*)	TRANSFORMER, power: step-down and step-up; fil and plate type; 115 v ac, 50/60 cyc, single ph input; #1 sec 500 v ac, 25 ma; #2 sec 6.3 v ac, 3.25 amp; #3 sec 5.0 v ac, 2.0 amp; #1 and #2 sec CT; HS steel case; 3 $\frac{1}{32}$ " lg x 2 $\frac{3}{32}$ " wd x 3 $\frac{5}{64}$ " h o/a; Chi Transf part #16213.	Same as T103 above-----	2Z9613.694
T104-----	(*)			TRANSFORMER, AF: limiter; pri 10,000 ohms; sec 80,000 ohms impedance; upright shielded; Gentrans #2A139; Hallicrafters part/dwg #55A036.	Couples plate of triode section of limiter amplifier V105 to diode plates of same tube.	2Z9634.2
T104-----		(*)	(*)	TRANSFORMER, AF: plate coupling type; pri impedance 10,000 ohms, sec 40,000 ohms CT; HS metal case; 1 $\frac{1}{2}$ " lg x 1 $\frac{1}{2}$ " wd x 2 $\frac{1}{8}$ " h o/a; Chi Transf part #14569A.	Same as T104 above-----	2Z9632.605

## INDEX

	<i>Paragraphs</i>	<i>Page</i>
Additional equipment.....	9	5
Alinement:		
Modulation limiter.....	51	36
Sidetone amplifier.....	52	37
Test equipment required.....	50	36
Application, system:		
General.....	4	1
Radio Set AN/GRC-26A.....	4	1
Radio Set AN/MRC-2 (*).....	4	1
Radio Sets SCR-399-(*) and SCR-499-(*).....	4	1
Arctic operation.....	22	11
Audio gain test.....	56	38
Block diagram, theory.....	31	14
Characteristics, technical.....	5	3
Chart, trouble-shooting.....	45	28
Checks, daily, weekly, and monthly.....	28	12
Coils, resistances.....	46	29
Compression (limiter) test.....	60	39
Connections.....	14	7
Controls and their function.....	17	8
Daily check.....	28	12
Data, trouble-shooting.....	42	28
Demolition, equipment:		
General.....	65	42
Methods.....	66	42
Description of Speech Amplifier BC-614-I.....	7	4
Desert operation.....	24	11
Distortion test.....	57	38
Dynamic microphone, theory.....	40	22
Equipment required, additional.....	9	5
First a-f amplifier:		
Function.....	31	14
Theory.....	32	14
Forms and records.....	2	1
Fourth a-f amplifier:		
Function.....	31	14
Theory.....	35	18
Hum level test.....	59	39
Installation:		
Siting (location).....	11	7
Tubes.....	13	7
Key jack.....	40	22
Lubrication.....	29	13
Microphone (carbon):		
Adjustment.....	19	10
Connection and control.....	17	8
Current test.....	62	41
Theory.....	40	22

	<i>Paragraphs</i>	<i>Page</i>
Microphone (dynamic):		
Adjustment .....	19	10
Connection and control .....	17	8
Theory .....	40	22
Modulation Limiter:		
Alinement .....	51	36
Function .....	31	14
Limiter control:		
Adjustment .....	51	36
Function .....	17	8
Replacement .....	48	36
Theory .....	40	22
Theory .....	36	18
Modulator plate meter .....	40	22
Monthly check .....	28	12
Operation:		
Arctic climates .....	22	11
Desert climates .....	24	11
General .....	21	11
Tropical climates .....	23	11
Types:		
C-w .....	19	10
Phone .....	19	10
Packaging data .....	6	4
Painting .....	30	13
Parts, replacement .....	48	36
Phase inverter:		
Function .....	31	14
Theory .....	34	17
Power supply:		
Function .....	31	14
Pilot lamp .....	17	8
Requirements .....	5, 9	3, 5
Theory .....	39	21
Precautions, trouble-shooting .....	48	36
Preventive maintenance:		
Daily check .....	28	12
Definition .....	25	12
Desert .....	28	12
Monthly check .....	28	12
Rustproofing and painting .....	30	13
Techniques .....	26	12
Tropical .....	29	13
Weekly check .....	28	12
Winter .....	29	13
Purpose, speech amplifier .....	3	1
Radio Set AN/GRC-26A, application of Speech Amplifier BC-614-I .....	4	1
Radio Set AN/MRC-2(*), application of Speech Amplifier BC-614-I .....	4	1
Radio Sets SCR-399-(*) and SCR-499-(*), application of Speech Amplifier BC-614-I .....	4	1
Repacking .....	64	42
Replacement of parts .....	48	36
Resistance measurements:		
B+ circuits .....	44	28
Coils .....	46	29
General .....	42	28
Transformers .....	46	29
Running spares .....	8	5
Rustproofing .....	30	13
Second a-f amplifier:		
Function .....	31	14
Theory .....	33	15

	<i>Paragraphs</i>	<i>Page</i>
Service upon receipt of used or reconditioned equipment.....	15	8
Sidetone:		
Amplifier:		
Alinement.....	52	37
Function.....	31	14
Sidetone volume control.....	40	22
Test, final.....	61	39
Theory.....	38	21
Oscillator:		
Function.....	31	14
Test, final.....	61	39
Theory.....	37	19
Signal tracing:		
General.....	41	27
Tests.....	47	29
Siting.....	11	7
Spares, running.....	8	5
Starting.....	18	10
Technical characteristics of Speech Amplifier BC-614-I.....	5	3
Telephone input:		
Audio gain test.....	56	38
Control (DYNAMIC MIC. 2).....	17	8
General.....	32	14
Test equipment required:		
Final testing.....	54	37
Modulation limiter adjustment.....	50	36
Sidetone volume adjustment.....	50	36
Trouble shooting.....	43	28
Tests, final:		
Audio gain.....	56	38
Carbon microphone current.....	62	41
Compression (limiter).....	60	39
Distortion.....	57	38
Fidelity.....	58	39
General.....	59	39
Hum level.....	59	39
Sidetone oscillator and amplifier.....	61	39
Test conditions.....	55	37
Test equipment required.....	54	37
Theory:		
Block diagram.....	31	14
Carbon microphone.....	40	22
Dynamic microphone.....	40	22
First a-f amplifier.....	32	14
Fourth a-f amplifier.....	35	18
Key jack.....	40	22
Modulation:		
Limiter.....	36	18
Limiter control.....	40	22
Plate meter.....	40	22
Phase inverter.....	34	17
Power supply.....	39	21
Second a-f amplifier.....	33	15
Sidetone:		
Amplifier.....	37	19
Oscillator.....	37	19
Volume control.....	40	22
Third a-f amplifier.....	34	17
Third a-f amplifier:		
Function.....	31	14
Theory.....	32	14
Transformers, resistances.....	46	29

	<i>Paragraphs</i>	<i>Page</i>
Tropical maintenance .....	29	13
Trouble shooting:		
Chart .....	45	28
Data .....	42	28
General procedures .....	41	27
Replacement of parts:		
Gain controls .....	48	36
Limiter controls .....	48	36
Resistance measurement:		
B+ circuits .....	44	28
Coils .....	46	29
General .....	44	28
Transformers .....	46	29
Signal tracing .....	47	29
Test equipment required .....	43	28
Visual inspection .....	41	27
Voltage measurements .....	44	28
Uncrating and unpacking new equipment .....	12	7
Use, speech amplifier .....	3	1
Visual inspection .....	41	27
Voltage measurements:		
General .....	44	28
Voltage charts .....	figs. 18 and 19	30, 31
Weatherproofing .....	29	13
Weekly check .....	28	12
Winter maintenance .....	29	13



**TM 11-5054/T0 16-40BC614-6**

**SPEECH AMPLIFIER, BC-614-E, -F, -H, AND -I—1952**